



BERGER
Grossbildprojektion
media event
Miet-Service
Tel. 0621/59 800-0
info@berger-me.de
berger-me.de

www.berger-me.de

info@berger-me.de



Professionelle Technik für Ihr Event

Ver. 2023-02

von Video , Full HD, 4K bei 60Hz mit 4:4:4 Farbabtastung

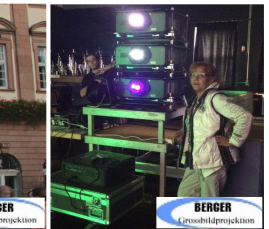



Eine der ersten Leitwarten der Welt ohne Monitore



Mietweise Überlassung

Mietaufträge müssen 1 Woche vor Einsatz schriftlich und im Detail geklärt bei uns vorliegen und von uns bestätigt sein. Andernfalls kann kein reibungsloser und rechtzeitiger Miettermin garantiert werden. Eine Haftung für Schäden und Personen, Sachen sowie deren Folgen durch unsere Geräte ist ausgeschlossen. Erfolgt nach Auftragserteilung ein Rücktritt, den der Mieter zu vertreten hat, so wird 50% des Mietpreises berechnet. Mietgeräte bleiben unser uneingeschränktes Eigentum. Eine Weiterveräußerung, Pfändung, Sicherheitsübereignung ist nicht zulässig. Bei Zugriff von Dritten insbesondere Gerichtsvollziehern auf die Mietgeräte, hat der Mieter auf das Eigentum des Vermieters hinzuweisen und diesen unverzüglich zu benachrichtigen. Die angegebenen Preise sind ausschließlich ein Entgelt für die Mietweise Überlassung und sind netto zzgl. der gesetzl. MwSt. Nicht eingeschlossen sind Transport, Hebevorrichtungen, Podeste, Gerüste, Lichttunnels bei Rückprojektionen, Abdunklungen, ... etc. Der Mieter besorgt sich selbst und auf eigene Kosten alle notwendigen Bewilligungen und trägt alle zu entrichtenden Gebühren für TV und Urheberrechte. Der Vermieter haftet für den funktionstüchtigen Zustand der Geräte nur bis zum Zeitpunkt der Übergabe. Bei Ausfall beschränkt sich der Schadensersatz auf den Mietpreis. Bei wichtigen Veranstaltungen empfiehlt sich deshalb der Einsatz von Backup Geräten. Vom Auftraggeber geforderte, jedoch nicht benutzte Reservegeräte werden mit 50 % des Mietpreises in Rechnung gestellt. Bei technischen Defekten während der Mietzeit hat der Mieter Anspruch auf schnellst möglichen Reparaturservice bzw. Bereitstellung eines Ersatzgerätes. Anfallende Reisekosten zum Einsatzort und zurück gehen zu Lasten des Mieters. Der Vermieter ist berechtigt, eine Vorauszahlung bis 50 % des voraussichtlichen Rechnungsbetrages zu verlangen. Diese Mietbedingungen gelten in Ergänzung zu den allgemeinen Geschäftsbedingungen der Firma **Berger**

Es gelten die AGB der Fa. **BERGER**

Änderungen und Irrtümer vorbehalten. Aktionszeitraum freibleibend.

1. Hochleistungs Projektoren 3 Chip DLP

	<p>Panasonic PT-RQ50K Laser</p> <ul style="list-style-type: none"> * 50.000 Lumen 3 DLP 163kg * 4096x2100 16:10 4k * Eingänge: DP; HDMI; SDI; HD BaseT * Stromanschluss: CEE32A 4100W * Laser Phosphor Technologie Mietpreis * mit Flugrahmen im Case. ohne Optik 	<p>M-PTRQ50K</p> 	
	<p>Panasonic PT-RQ35 Laser</p> <ul style="list-style-type: none"> * 32.000 Lumen 3 DLP 163kg * 4096x2100 16:10 4k * Eingänge: DP; HDMI; SDI; HD BaseT * Stromanschluss: CEE32A * Laser Phosphor Technologie Mietpreis * mit Flugrahmen im Case. ohne Optik 	<p>M-PTRQ35K</p> 	
	<p>Panasonic PT-RQ34 Laser</p> <ul style="list-style-type: none"> * 32.000 Lumen 3 DLP 163kg * 1920x1200 16:10 1080p HD * Eingänge: DP; HDMI; SDI; HD BaseT * Stromanschluss: CEE32A * Laser Phosphor Technologie Mietpreis * mit Flugrahmen im Case. ohne Optik 	<p>M-PTRQ34K</p> 	
	<p>Panasonic PT-RZ31K Laser</p> <ul style="list-style-type: none"> * 30.000 Lumen 3 DLP 116kg * 1920x1200 16:10 1080p HD * Eingänge: DVI; HDMI; SDI; Analog * Stromanschluss: CEE32A 2870W * Laser Phosphor Technologie Mietpreis * mit Flugrahmen und Case ohne Optik 	<p>M-PTRZ31K</p> 	
	<p>Panasonic PT-DZ21K</p> <ul style="list-style-type: none"> * 20.000 Lumen 3 DLP * 1920x1200 16:10 1080p HD * Eingänge: DVI; HDMI; SDI; Analog * Stromanschluss: Schukostecker auf IEC 19 * 4 Lampen Technologie * mit Flugrahmen und Case. Mit einer Optik LE-3 oder LE-4 	<p>M-P21K</p>  	
	<p>Panasonic PT-DW10000</p> <ul style="list-style-type: none"> * 10.000 Ansi Lumen 32kg * 1920x1080 16:09 1080p HD * Eingänge: DVI; HDMI; SDI; Analog * Stromanschluss: Schukostecker auf IEC 19 * 4 Lampen Technologie 4x 250W 1.450W * mit Flugrahmen und Case. Mit einer Optik LE-3 oder LE-4 	<p>M-P10000DW</p>  	

Wechsel Objektiv für Panasonic DLP Projektoren

	Panasonic Objektiv	M-ETD75LE90		
	* ET-D75LE90			
	* 0,39 : 1			
	* WUXGA / HDTV 0,36 : 1			
	* kompatible Produkte: PT-DW, PT-DZ, PT-D, PT-RQ			

	Panasonic Objektiv	M-ETD75LE5		
	* ET-D75LE50			
	* 0,8 : 1			
	* WUXGA / HDTV 0,7 : 1			
	* kompatible Produkte: PT-DW, PT-DZ, PT-D, PT-RQ			

	Panasonic Objektiv	M-ET-D75LE10		
	* ET-D75LE10			
	* 1,4 - 1,9 : 1			
	* WUXGA / HDTV 1,3 - 1,7:1			
	* kompatible Produkte: PT-DW, PT-DZ, PT-D, PT-RQ			

	Panasonic Objektiv	M-ETD75LE20		
	* ET-D75LE20			
	* 1,8 - 2,6 : 1			
	* WUXGA / HDTV 1,7 - 2,4:1			
	* kompatible Produkte: PT-DW, PT-DZ, PT-D, PT-RQ			

	Panasonic Objektiv	M-ETD75LE30		
	* ET-D75LE30			
	* 2,7 - 5,2 : 1			
	* WUXGA / HDTV 2,6 - 5,1:1			
	* kompatible Produkte: PT-DW, PT-DZ, PT-D, PT-RQ			

	Panasonic Objektiv	M-ETD75LE40		
	* ET-D75LE40			
	* 6,7 - 10:1			
	* DW10000 4,6 - 7,4 :1			
	* kompatible Produkte: PT-DW, PT-DZ, PT-D, PT-RQ			

	Panasonic Objektiv	M-ETD75LE3 M-ETD75LE4		
	* ET-D75LE3 2,8 - 4,6 :1			
	* ET-D75LE4 4,6 - 7,4 :1			
	* DW10000			
	* kompatible Produkte: PT-DW, PT-DZ, PT-D, PT-RQ			

2. Epson Laser Projektoren

	Epson EB-L25000U	M-EB25000u		
	<ul style="list-style-type: none"> * 3LCD WUXGA Laser Projektor * 25.000 ANSI Lumen * 4K Enhancement * Laser Lichtquellentechnologie * Flexible 360° Installation * Gewicht : 66,6kg 			

	Epson EB-L30000U	M-EB30000u		
	<ul style="list-style-type: none"> * 3LCD WUXGA Laser Projektor * 30.000 ANSI Lumen * 4K Enhancement * Laser Lichtquellentechnologie * Flexible 360° Installation * Gewicht : 63,8kg 			

	Epson EB-L1755U	M-EB1755u		
	<ul style="list-style-type: none"> * 3LCD WUXGA Laser Projektor * 15.000 ANSI Lumen * 4K Enhancement * Laser Lichtquellentechnologie * Flexible 360° Installation * Gewicht : 21kg 			

	Epson EB-L1505U	M-EB1505u		
	<ul style="list-style-type: none"> * 3LCD WUXGA Laser Projektor * 12.000 ANSI LUMEN * 4K Enhancement * Laser Lichtquellentechnologie * Flexible 360° Installation * Gewicht : 24kg 			

	Epson EB-L1100U	M-EB1100		
	<ul style="list-style-type: none"> * 3LCD WUXGA Laser Projektor * 6.000 ANSI LUMEN * 4K Enhancement * Laser Lichtquellentechnologie * Flexible 360° Installation * Gewicht : 21kg 			

Objektive für Epson Laserprojektoren

	Objektiv ELPLM15	M-ELPLM15		
	<ul style="list-style-type: none"> * Projektionsfaktor: 1,58 - 2,56 : 1 * Zoom Objektiv 			
	Objektiv für EB-G7200W / G7400U / G7900U / G7905U / L1100U / L1200U/ L1300U / L1405U			
	Das Objektiv Epson ELPLM15 ist der Nachfolger des Epson Objektivs ELPLM09.			



	Objektiv ELPLM10	M-ELPLM10		
	<ul style="list-style-type: none"> * Projektionsfaktor: 2,43 - 3,71 : 1 * Zoom Objektiv 			
	Objektiv für EB-G7200W / G7400U / G7900U / G7905U / L1100U / L1200U/ L1300U / L1405U			

	Objektiv ELPLM11	M-ELPLM11		
	<ul style="list-style-type: none"> * Projektionsfaktor: 3,54 - 5,41 : 1 * Zoom Objektiv 			
	Objektiv für EB-G7200W / G7400U / G7900U / G7905U / L1100U / L1200U/ L1300U / L1405U			

	Objektiv ELPLL08	M-ELPLL08		
	<ul style="list-style-type: none"> * Projektionsfaktor: 5,28 - 7,72 : 1 * Zoom Objektiv 			
	Objektiv für EB-G7200W / G7400U / G7900U / G7905U / L1100U / L1200U/ L1300U / L1405U			

	Objektiv ELPLX02-UST	M-ELPLX02		
	<ul style="list-style-type: none"> * Throw Ratio Projektionsfaktor: 0,35 : 1 * Ultra Short Objektiv für Epson L15000 und L12000 			

NEC Laser Projektore 20.000 Ansi

 <p>NEC PX2201 NEC PX2000UL</p> <ul style="list-style-type: none"> * Laserprojektor DLP * 20.500 Ansi Lumen * Auflösung: 1920 x 1200 * * Gewicht: 51kg 		M-PX2201		

Objektive für NEC PX Laserprojektoren

	<p>NEC Objektiv NP46ZL 100015402</p> <ul style="list-style-type: none"> * Short-Zoom-Wechselobjektiv für PX2000UL und PX2201UL * Projektionsfaktor: 1,2 -1,156 :1 	M-NP46ZL		



	<p>NEC Objektiv NP47ZL 100015403</p> <ul style="list-style-type: none"> * Standard-Wechselobjektiv für PX2000UL und PX2201UL * Projektionsfaktor: 1,5 -2,1 : 1 	M-NP47ZL		

	<p>NEC Objektiv NP48ZL 100015404</p> <ul style="list-style-type: none"> * Long-Zoom-Wechselobjektiv für PX2000UL und PX2201UL * Projektionsfaktor: 2,0 - 4,0 : 1 	M-NP48ZL		





	<p>NEC Objektiv NP49ZL 100015405</p> <ul style="list-style-type: none"> * Extra Long-Zoom-Wechselobjektiv für PX2000UL und PX2201UL * Projektionsfaktor: 4,0 - 7,0 : 1 	M-NP49ZL		



	<p>NEC Objektiv NP49ZL 100015400</p> <ul style="list-style-type: none"> * UltraWeitwinkel-Wechselobjektiv für PX2000UL und PX2201UL * Projektionsfaktor: 0,9 - 1.21 : 1 	M-NP45ZL		

NEC Laser 8000 und 10000 Ansi

	NEC PA 804UL	M-PA804UL	
	<ul style="list-style-type: none"> * Laser Projektor LCD * Auflösung: 1920 x 1200 ◦ Helligkeit: 8200 ANSI Lumen * Gewicht: 24,1kg 		
	NEC PA 1004UL	M-PA1004UL	
	<ul style="list-style-type: none"> * Laser Projektor LCD * Auflösung: 1920 x 1200 ◦ Helligkeit: 10.00 ANSI Lumen * Gewicht: 24,1kg 		

Objektive NEC Laser PA Serie

	NEC Objektiv NP11FL	60003222	M-NP11FL	
	<ul style="list-style-type: none"> * Fixes Weitwinkel-Wechselobjektiv für NEC PA Serie * Projektionsfaktor: 0,8 : 1 ◦ 			
	NEC Objektiv NP12FL	60003220	M-NP12FL	
	<ul style="list-style-type: none"> * Short Zoom Weitwinkel-Wechselobjektiv für NEC PA Serie * Projektionsfaktor: 1,16 - 1,56 : 1 ◦ 			
	NEC Objektiv NP13ZL	60003217	M-NP13ZL	
	<ul style="list-style-type: none"> * Middle Zoom Wechselobjektiv für NEC PA Serie * Projektionsfaktor: 1,46 - 2,95 : 1 ◦ 			
	NEC Objektiv NP14ZL	60003221	M-NP14ZL	
	<ul style="list-style-type: none"> * Middle Zoom Wechselobjektiv für NEC PA Serie * Projektionsfaktor: 2,9 - 4,68 : 1 ◦ 			

	<p>NEC Objektiv NP15ZL 60003219</p> <ul style="list-style-type: none">* Middle Zoom Wechselobjektiv für NEC PA Serie* Projektionsfaktor: 4,7 - 7,2 : 1o	M-NP15ZL	
	<p>NEC Objektiv NP44-ML-PA4 100015549</p> <ul style="list-style-type: none">* Ultra Short Wechselobjektiv für NEC PAXx7UL Serie* Projektionsfaktor: 0,32 : 1o	M-NP44ML	

3 Chip DLP Hochleistungs Projektor VGA Klasse

	Panasonic 9500 * 10.000 ANSI Lumen * Auflösung: 1024x768 XGA * Lampe: 1600W Xenon Anschluss: 2.300W * Stromanschluss: Schuko Stecker auf IEC 19 * mit Flugrahmen und Case, Gewicht 98kg	M-P9500		

Objektive für den Panasonic DLP Projektor 9500 1024x768

	◦ Objektiv 1,0 : 1 ◦ Zoom Objektiv 1,2 - 2,5 : 1 ◦ Zoom Objektiv 2,5 - 4,0 : 1 ◦ Zoom Objektiv 4,0 - 7,0 : 1	M-9500-10		
		M-9500-1225		
		M-9500-2540		
		M-9500-4070		

EIKI LCD Projektoren VGA 1024x768

	EIKI LC-XT5 * 15.000 ANSI Lumen * Auflösung: 1024x768 * 4 Lampen UHP 400W * Anschluss: 2000W * Gewicht: 38kg	M-EIKIXT5		

	EIKI LC-XT4 * 12.000 ANSI Lumen * Auflösung: 1024x768 * 4 Lampen UHP 300W * Anschluss: 1700W * Gewicht: 38kg	M-EIKIXT4		

	EIKI LC-XT3 * 10.000 ANSI Lumen * Auflösung: 1024x768 * 4 Lampen UHP 250W * Anschluss: 1500W * Gewicht: 38kg	M-EIKIXT3		

Objektive für Eiki LC-XTx Projektoren

	◦ Objektiv 0,82 : 1 ◦ Objektiv 1,22 : 1 ◦ Zoom Objektiv 2,65 - 3,58 : 1 ◦ Zoom Objektiv 3,40 - 4,40 : 1 ◦ Zoom Objektiv 4,32 - 6,04 : 1 ◦ Zoom Objektiv 6,12 - 8,92 : 1	M-EIL32021		
		M-EIL21012		
		M-EIL22051		
		M-EIL21022		
		M-EIL21091		
		M-EIL32581		

LCD Projektoren FULL HD 6000 ANSI Lumen Klasse

	Epson EB-Z8000 WU * 6.000 ANSI LUMEN * WUXGA 1920 x1200 * * *	M-EZ8000		
				



	Epson EB-Z8050 W * 7.000 ANSI LUMEN * WXGA 1280 x 800 * * *	M-EZ8050		
				



Objektive für Epson Projektoren der Serie Z8000 und Z8050



	◦ Zoom Objektiv 1,71 -2,78 : 1 Standard Zoom	3-MEP-ELPS04		
	◦ Zoom Objektiv 1,29 -1,77 : 1 WIDE	3-MEP-ELPW04		
	◦ Zoom Objektiv 2,64 - 4,83 : 1 MID Throw	3-MEP-ELPM06		
	◦ Zoom Objektiv 3,85 - 5,88 : 1 MID Throw	3-MEP-ELM07		
	◦ Zoom Objektiv 5,76 - 8,09 : 1 Long Throw	3-MEP-ELPL07		

	Epson EB-G7900U * 7.000 ANSI Lumen * WUXGA 1920x1200 * 4K Enhancement * HDBaseT * Lensshift	M-E7900		
				

	NEC PE 605UL ◦ LaserProjektor ◦ Auflösung: 1920 x 1200 ◦ Helligkeit: 6000 Ansi Lumen ◦ Gewicht: 9,7kg * Lensshift	60004811 M-PE605UL		
				



	NEC P525UL * Laser Phosphor Lichtquelle * 5.000 ANSI Lumen * 1920x1080 * Objektiv: 1,24 -2,1 : 1 * Gewicht: 9,7kg *	M-N-P525UL		
				

	Epson EB-2265U	M-E2265u	
	<ul style="list-style-type: none"> * 5.500 ANSI Lumen * WUXGA 1920x1200 * Objektiv: 1,26 - 2,30 : 1 		

	Epson EB-U32	M-EB32U	
	<ul style="list-style-type: none"> * 3.200 ANSI Lumen * WUXGA 1920x1200 * Objektiv: 1,38 - 1,68 : 1 * * * 		

	Epson EB 1795	M-E-EB1795	
	<ul style="list-style-type: none"> * 3.200 ANSI Lumen * WUXGA 1920x1200 * Objektiv: 1,38 - 1,68 : 1 		

	NEC P420X	M-N-P420X	
	<ul style="list-style-type: none"> * 4.200 ANSI Lumen * XGA 1024x768 * Objektiv: 1,3 - 2,2 : 1 * Vertical Lensschift 		

	Epson EB 696ui	M-EB696ui		
	<ul style="list-style-type: none"> * interaktiv (touch) incl. Smart Software * WUXGA 1920x1200 * Objektiv: 0,27- 0,37 : 1 * 3.000 ANSI Lumen * Bilddiagonale bis 2,54m 			

	NEC U 300X 3.000 ANSI	M-NU300X		
	<ul style="list-style-type: none"> * Ultra short: 0,37 : 1 * Aspect Ratio: 16:10 * max Resolution: UXGA 1600 x 1200 * nativ Resolution: XGA 1024x768 * Auto Keystone Correction * 			

	NEC U 310W 3.100 ANSI	M-NU310W		
	<ul style="list-style-type: none"> * Ultra short: 0,37 : 1 * Aspect Ratio: 16:10 * max Resolution: 1600 x 1200 * nativ Resolution: WXGA 1280x800 * Auto Keystone Correction * 			

	NEC U 330wi 3.300 ANSI	M-N330wi		
	<ul style="list-style-type: none"> * Ultra short: 0,37 : 1 * Aspect Ratio: 16:10 * max Resolution: 1600 x 1200 * nativ Resolution: XGA 1024x768 * Auto Keystone Correction 			

	NEC U 351W	M-N351wi		
	<ul style="list-style-type: none"> * Ultra short: 0,36 : 1 * Aspect Ratio: 16:10 * max Resolution: 1920 x 1200 * nativ Resolution: WXGA 1280x800 * Auto Keystone Correction 			

	EPSON EH-TW9200W	M-3DE9200W		
	<ul style="list-style-type: none"> * 3D Projektion auf eine weiße Leinwand * Full HD 1920x1080 * 2.400 ANSI Lumen * mit 2 3D Brillen 			

Projektor VGA 1024x768



NEC GT 5000

- * 6.000 ANSI Lumen
- * 1024x768
- * Full HD kompatibel
- * DCDi by Faroudja Video Decoder

M-GT5000

Projektor VGA 1400x1050



NEC GT 6000

- * 5.000 ANSI Lumen
- * 1400x1050
- * Full HD kompatibel
- * DCDi by Faroudja Video Decoder

M-GT6000

Objektive für NEC Projektoren der Serie GT 5000 und GT 6000



- Zoom Objektiv GT13 ZLB** 1,3 - 1,6 : 1
- Zoom Objektiv GT19 ZLB** 1,8 - 2,2 : 1
- Zoom Objektiv GT20 ZLB** 2,0 - 2,6 : 1
- Zoom Objektiv GT34 ZLB** 3,2 - 4,8 : 1

M-NL20023

M-NL20022

M-NL23176

M-NL20011

1 Chip DLP Prjektoren mit VGA Auflösung



NEC PX800

- * 8.000 ANSI Lumen
- * 1024x768 VGA
- * Std Objektiv 1,78 - 2,35

M-PX800



NEC NP4100

- * 6.200 ANSI Lumen
- * 1024x768 VGA
- * Std Objektiv 1,78 - 2,35

M-NP4100

Objektive für die Projektoren NP400, NP4100, PX750 und PX800



- * Wechsel Objektiv 1,25 - 1,79
- * Wechsel Objektiv 1,78 - 2,35
- * Wechsel Objektiv 2,22 - 4,43
- * Wechsel Objektiv 3,50 - 5,41
- * Wechsel Objektiv 4,34 - 8,03

M-NL3225

M-NLP08ZL

M-NLP08ZL

M-NLP09ZL

M-NLP10ZL

LED Wände



Bild: Hifi Klang Elektronische Medien / Siege Bildnachweise

LED Wände Outdoor Trucks

- * 31 m² Pixelabstand: 10mm; 5000cd/m²; 63A/400V
- * 51 m² Pixelabstand: 10mm; 6000cd/m²; 63A/400V

auf Anfrage		
auf Anfrage		
auf Anfrage		



Bild: Hifi

LED Wände Outdoor Trailer

- * 15 m² Pixelabstand: 10mm; 6500cd/m²; 16A/400V
- * 16 m² Pixelabstand: 8mm; 5500cd/m²; 16A/400V
- * 18 m² Pixelabstand: 10mm; 6500cd/m²; 32A/400V
- * 21 m² Pixelabstand: 3,9mm; 5000cd/m²; 32A/400V

auf Anfrage		
auf Anfrage		
auf Anfrage		
auf Anfrage		



Bild: Hifi Klang Elektronische Medien / Siege Bildnachweise

LED Wände Indoor

- * UNILUMIN VENTURE II
- * Pixelpitch: 2,60 mm
- * Eck-Bauweise möglich
- * bis 4,00 x 7,5m

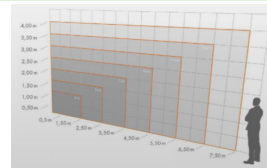

auf Anfrage		

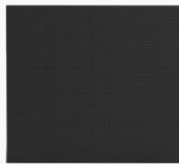

LED Wände Indoor

- * LIANTRONICS PH3.1PRO
- * Pixelpitch: 3,1 mm
- * Eck-Bauweise möglich
- * bis 4,00 x 7,5m

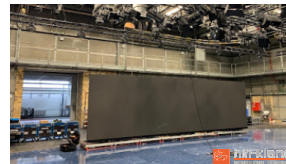

auf Anfrage		



LEDMAN 4mm SMD 3 in 1

- * Pixelpitch: 4mm
- * 2000 Nits

auf Anfrage		

DESAY E4 4mm SMD 3 in 1

- * Pixelpitch: 4mm
- * 1500 Nits

auf Anfrage		



Bild: Hifi Klang Elektronische Medien / Siege Bildnachweise

Mobil LED Wand Indoor

- * 5,72 m² Pixelabstand: 4mm; 1500cd/m²; 32A/400V
- * 140" D
- * Transport: 2x540kg



auf Anfrage		



Bild: Hifi Klang Elektronische Medien / Siege Bildnachweise

Transparent LED Screen

- * ROE CREATIVE DISPLAY Vanish V8
- * 8,94 mm Pixel Pitch
- * Konkaver und konvexer Aufbau möglich
- * <https://www.youtube.com/watch?v=uexDVgEFP7s>

auf Anfrage		

Projektions Zubehör

	DSAN PerfectCue	M-PCUE		
	<ul style="list-style-type: none"> * Fernsteuerung der Präsentationssoftware * 433 MHz * im Koffer mit 2 Sender 			

	DSAN PerfectCue 4	M-PCUE-4USB		
	<ul style="list-style-type: none"> * Fernsteuerung der Präsentationssoftware * 433 MHz * im Koffer mit 3 Sender 			

	Logitech Funk Presenter	M-Funkmouse			
	<ul style="list-style-type: none"> * bis 30m Reichweite * intuitive Bedienelemente * Leuchtend roter Laserpointer * Kabelloser Pug und Play Empfänger * CE Zeichen 	2,4GHz	<small>EMCD Richtlinie 2014/30/EU / EMCD directive 2014/30/EU EN 55015-1:2013 +A2:2015 EN 61547:2009 EN 61000-3-2:2014 EN 61000-3-3:2013</small>		
			<small>LVD Richtlinie 2014/35/EU / LVD directive 2014/35/EU EN 60825-1:2014</small>		
			<small>RoHS Richtlinie 2011/65/EU / RoHS directive 2011/65/EU</small>		

	Laser Pointer	M-LaserPgr		
	<ul style="list-style-type: none"> * grüner festkörper Laser * Leistung weniger als 1 mW * bis 13 mal besser sichtbar als rot 			

	Notebook Timer App und Uhrzeit	M-LAPUHR		
	<ul style="list-style-type: none"> * Notebook mit Uhr und Timer App * Aktuelle Uhrzeit und Timer * Countdown mit Redezeit / Diskussions Ende * Anzeige auf dem Mitschau-Monitor * Python Programm ccfg2015 * einfach zu bedienen 			

	Interspace industries Countdown Touch	M-Ctinterspace		
	<ul style="list-style-type: none"> * Countdown * Timing System * Redezeit Ende 			

ClickShare

	ClickShare Barco CS 100 CX10	M-B-CS100-1			
	<ul style="list-style-type: none"> * Auflösung: 1920 x 1200 * Bildrate bis 30 * Reichweite bis 30m * Protokoll: WPA2 				

	ClickShare Barco CS 200 CX20	M-B-CS200-2			
	<ul style="list-style-type: none"> * Auflösung: 1920 x 1200 * Bildrate bis 30 * Reichweite bis 30m * Protokoll: WPA2 				

	ClickShare Barco CS 800 CX50	M-B-CS800-4			
	<ul style="list-style-type: none"> * Auflösung: 4K 4096 x 2160 bi 60Hz * Bildrate bis 60 fps * Reichweite bis 30m * Protokoll: WPA2 oder IEEE802.1 * Video Eingänge: 2x HDMI Video Ausgänge: 2x HDMI 				

	Klick + Show Kindermann Kit	M-KiCS			
	<ul style="list-style-type: none"> * Drahtloses Präsentationssystem * PC/ Mac kompatibel * Low Latency 1080p <130ms * Secure AES WPA2PSK Authentifizierung * WLAN Accesspoint mit IEEE 802.11n/ac 				

Traversenhalterung

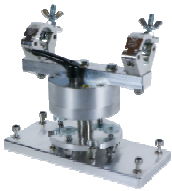
	Traversenhalterung Shorty-350-8/10	M-Shorty-350			
	<ul style="list-style-type: none"> * Professionelle Montage bis 350kg * Schwenk und Neigeverstellung * Grob und Feinjustage * Trusshalterung BGV-C1 zertifiziert * TÜV Abnahme der C-Schelle 				

	Traversenhalterung Shorty-150-8	M-Shorty-150			
	<ul style="list-style-type: none"> * Professionelle Montage bis 150kg * Schwenk und Neigeverstellung * Grob und Feinjustage * Trusshalterung BGV-C1 zertifiziert * TÜV Abnahme der C-Schelle 				

Tische

	Beamer Tisch * Rollbar * Höhenverstellbar * 60 - 85 cm	M-M-Tisch		

	Karba Tisch Schwarz * zum Koffer zerlegbar * einfacher Aufbau * 1,25 - 1,75 Höhe * einfach zu transportieren	M-Karba		

Traversen Design Säule

	Traversen Design Säule * Höhe 2m * Bodenplatte Metall 0,8x0,8m * Top-Platte Holz 0,8x0,8m	M-GLI-Video		

Ground Loop Isolator

	Ground Loop Isolator HD-SDI / SDI * HDSDI - HDSDI * Galvanische Trennung	M-GLI-HDSDI		
				

	Ground Loop Isolator HD-SDI / SDI 4K * HDSDI - HDSDI * Galvanische Trennung * 4K / 12G	M-GLI-HDSDI4k		
				

	Ground Loop Isolator VIDEO * Video / Video * Galvanische Trennung	M-GLI-Video		
				

	LAN Isolator * RJ45 / RJ45 * Lan Isolator * * *	M-RJ45I		

	HD Media Player * USB Play * HDMI * 1080p/60	M-WDMP		

	XT 1143 professioneller Mediaplayer * BrightSign 4k Player * 4k/60 Video, streaming * SD Karte USB Play * H265, H264, * HTML 5	M-XT1143		

	Stumpfl FHD Player * Video Player * Auflösung: 1920x1080 Full HD * Video Formate: MPEG4, JPEG, WMV, MOV, H264 * Dateisystem: SD Karte, USB Stick, USB Festplatte	M-STFHD-Player		

	Stumpfl UHD Player * Video Player * Auflösung: 3840x2160 4K * Datenspeicher Medien: SDHC; USB 3.0 * Netzwerk: Gigabit LAN	M-STUHD-Player		

	Raspberry Pi Media Player * USB AUTO Play * HDMI 1920x1080 * 1080p/60 * Video Formate: MPEG4, JPEG, H264	M-Raspi-4B		



	PC Lautsprecher * Multimedia Lautsprecher * Logitech Z120 * Stromversorgung über USB	M-Z120		

	PC Lautsprecher * Multimedia Lautsprecher * Full Range Audio	M-PCLS		

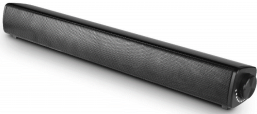
	<p>PC Lautsprecher weiß</p> <ul style="list-style-type: none"> * Multimedia Lautsprecher * Full Range Audio * Logitech Z200 	M-Z200		

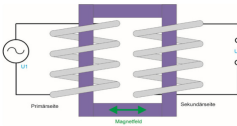
	<p>Soundbar</p> <ul style="list-style-type: none"> * 180W * Fernbedienung 	M-SB180		

	<p>Trenntrafo</p> <ul style="list-style-type: none"> * 1000W / 2500W / 3500W * 230V / 230V * Galvanische Trennung 	M-TT1000			

	<p>Grundig VG1000</p> <ul style="list-style-type: none"> * Referenz Testbild Generator * Video 	M-VG1000			

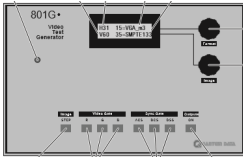
	<p>Quantum 801</p> <ul style="list-style-type: none"> * Referenz Testbild Generator 	M-Q801			



	<p>Quantum 780</p> <ul style="list-style-type: none"> * Referenz Testbild Generator * * * https://www.youtube.com/watch?v=CzBrasF2Xso 	M-Q780		

3D Projektion

In einem Forschungsprojekt der Daimler AG (ehemalige DaimlerChrysler AG) in Ulm wurde im Jahr 1999 unter der Bezeichnung Wellenlängenmultiplex-Visualisierungs-Systeme untersucht, in wie weit der neue technische Ansatz für eine verbesserte und funktional erweiterte Bilderzeugung in Virtual-Reality-Systemen geeignet ist. Für das aus diesem sehr erfolgreichen Projekt hervorgegangene Verfahren wurde die Marke INFITEC® eingetragen, die seitdem eine bedeutende Stellung in der 3D-Visualisierungsindustrie einnimmt. 2015 hat INFITEC® ihre neue 6P-3D-Brille speziell für Laser-Projektion auf dem Markt eingeführt.

Quelle: 



 Excellence in 3D UHP filter cap set HST D79 (Panasonic 3-DLP) 	Infitec Filterset * Projektorbezogene Kits 	auf Anfrage	<table border="1"> <tr><td></td><td></td></tr> <tr><td></td><td></td></tr> <tr><td></td><td></td></tr> <tr><td></td><td></td></tr> <tr><td></td><td></td></tr> <tr><td></td><td></td></tr> </table>												

	Infitec 3D Brillen * bis zu 3000 3D-Brillen verfügbar * Reinigung mit Glasreiniger; Isopropyl Alkohol, warmem Wasser * nach dem Reinigen bitte trocknen * keine scharfe Reinigungsmittel verwenden	Auf Anfrage	<table border="1"> <tr><td></td><td></td></tr> <tr><td></td><td></td></tr> <tr><td></td><td></td></tr> <tr><td></td><td></td></tr> <tr><td></td><td></td></tr> <tr><td></td><td></td></tr> </table>												

	3D Projektoren Set 21k mit Infitec * 2x 20.000 Ansi Lumen * Aufprojektion * Rückprojektion * Das Bild zeigt 3 Panasonic DZ21K in einer Rückprojektion	auf Anfrage	<table border="1"> <tr><td></td><td></td></tr> <tr><td></td><td></td></tr> <tr><td></td><td></td></tr> <tr><td></td><td></td></tr> <tr><td></td><td></td></tr> <tr><td></td><td></td></tr> </table>												

	3D Projektoren Set DW mit Infitec * 2x 10.000 Ansi Lumen * Aufprojektion * Rückprojektion	auf Anfrage	<table border="1"> <tr><td></td><td></td></tr> <tr><td></td><td></td></tr> <tr><td></td><td></td></tr> <tr><td></td><td></td></tr> <tr><td></td><td></td></tr> <tr><td></td><td></td></tr> </table>												

	3D Projektoren Set Z8000 * 2x 6.000 Ansi Lumen * Aufprojektion * Rückprojektion	auf Anfrage	<table border="1"> <tr><td></td><td></td></tr> <tr><td></td><td></td></tr> <tr><td></td><td></td></tr> <tr><td></td><td></td></tr> <tr><td></td><td></td></tr> <tr><td></td><td></td></tr> </table>												

Bild Regie



BARCO e2 Full-sized Master Processor

M-Barco-e2

- * 4K Screen Management System
- * Live Bildschirmmanagement
- * Erstklassige Bildqualität
- * 4K Output
- * wird nur mit Techniker vermietet



EC 50 BARCO e2 Event Controller

M-Barco-EC50

- * Full Control für Event Master
- * Internes 15,6" Touchscreen mit 10 Punkt Multitouch
- * 8 Ebenen
- * Hochauflösender T Hebel
- * wird nur mit Techniker vermietet



Eikos 4K

M-Eikos4K

- * Nahtlose 4k/60 HDMI und Displayport Umschalter
- * Zahlreiche Übergangseffekte
- * Multiviewer: Edge-Blending; Uhr; Timer; Countdown
- * Auflösungen bis 4k/60 4:2:2
- * Datenraten bis 18Gbps



Ross Carbonite Solo 1

M-Solo1

- * kompakter 1 HE Mischer
- * 9 Inputs 6 HDSDI und 3 HDMI
- * 6 Outputs HDSDI und 1HDMI
- * 720p; 1080i; 1080p
- * 480i; 576i



Panasonic AG-HMX 100EJ

M-PA-HMX100

- * kompakter Multiformat Bildmischer **HDSDI**
- * 9 Inputs 4 HDSDI; 2HDMI; 1 DVI-D; 4SD-SDI; 2 FBAS
- * 6 Outputs 4 HDSDI und 2 DVI-D (PGM und MV)
- * Audio Mischer
- * 3D Mischer





OPS 200

M-AW-OPS200

- * Multilayer Hi-Resolution seamless Switcher
- * 3 Scaler
- * Inputs: 3 Analog; 2 DVI; 2 3GHD-SDI
- * Outputs: 2 Analog; 2 Digital DVI (PGM und PREW)

Bild Regie



	ISS608		M-ISS608			
	<ul style="list-style-type: none"> * Nahtlose 4k/60 HDMI und Displayport Umschalter * Zahlreiche Übergangseffekte * Extron Vector 4k Skalierer * Auflösungen bis 4k/60 4:4:4 * Datenraten bis 18Gbps * IN: 6HDMI; 2DP OUT: HDMI 					

	ISS612	HDSDI	NEU	M-ISS612			
	<ul style="list-style-type: none"> * Nahtlose 4k/60 HDMI und Displayport Umschalter * Zahlreiche Übergangseffekte * Extron Vector 4k Skalierer * Auflösungen bis 4k/60 4:4:4 * Datenraten bis 18Gbps * IN: 6HDMI; 2DP; 4HDSDI OUT: HDMI; HDSDI 						

	PLS 350-3G		M-AW-PLS350			
	<ul style="list-style-type: none"> * Multilayer Hi-Resolution seamles Switcher mit HDSDI out * 3 Scaler * Inputs: 4 Analog; 4 DVI; 2 3GHD-SDI; 4HDMI * Outputs: 2 Analog; 2 Digital DVI (PGM und Pre) * HD-SDI OUT 					

	Extron DTP CrossPoint 84		M-DTPCS84			
	<ul style="list-style-type: none"> * 8x4 Kreuzschiene für 4K, Skalierer, Audio-DSP-Prozessor * Zwei DTP- und sechs HDMI-Eingänge * Zwei HDMI- und zwei unabhängig skalierte DTP-Ausgänge * Unterstützt 4K-Signale an allen Eingängen und beiden HDMI-Ausgängen 					

	Sony UVW 1200		M-UVW1200			
	<ul style="list-style-type: none"> * Sony Beta SP UVW 1200 Player * Reference Input: BNC 1.0Vp-p, 75 ohms, unbalanced sync negative * RGB/Component Output: BNC x3 * Video Output 1: BNC 1.0Vp-p, 75 ohms, unbalanced sync negative * Power Consumption: 63W 					

	Panasonic AG-7330					
	<ul style="list-style-type: none"> * Professional SVHS Video Recorder * S-VHS Broadcast PAL/NTSC 					
						

Kamera Technik



Panasonic AW-UE100W

PTZ 4k

P-AW-UE100

- * 4K 60p/50p PTZ-Kamera mit NDI und SRT
- * Inklusive Weitwinkelobjektiv mit 24-fachem optischem Zoom
- * verbesserte Reaktionsfähigkeit von Schwenken und Neigen
- * Optische Bildstabilisierung (OIS)



AW-HE130KE HD

PTZ

M-PAWHE130HD

- * Dom Systemkamera Full HD
- * 20 fach Optischer Motorzoom
- * Optischer Bildstabilisator
- * 3G-SDI Ausgang
- * PoE Stromversorgung



AW-HE20

PTZ

M-PAWHE20

- * Dom Systemkamera Full HD
- * 20 fach Optischer Motorzoom
- * Optischer Bildstabilisator
- * 3G-SDI, HDMI und USB Ausgang
- * PoE Stromversorgung



JVC GY-HD 251 Pro HD

M-JVC-GYHD251

- * 1/3" CCD Pro HD Camcorder
- * FULL HD 1920x1080 1080i und 1080p
- * Out HD-SDI Uncompressed
- * Canon Zoom Objektiv 20fach



Panasonic AG-HPX250AEJ

M-PA-HPX250

- * 1/3" Full HD 3CMOS P2HD Camcorder
- * HDMI und HD-SDI Ausgang
- * FULL HD 1920x1080 1080i und 1080p
- * Optischer Bildstabilisator



GoPro HERO 4

M-HERO4

- * Professionelle Aktionskamera
- * Weitwinkelobjektiv
- * 12Megapixel
- * 1080p/60

Kamera Technik



Gimbal 3 Achsen

- * für GoPro
- * Motor

M-Gimbal-GP



Panasonic AW-RP60G

- * neuer Joystick unterstützt eine weiche Schwenk-, Neige-Steuerung
- * 3,5" LCD
- * 4 benutzerdefinierbare Tasten für bis zu 8 Funktionen
- * PoE-Unterstützung / Erweiterte Kameraeinstellungen

M-PAWRP60



AW-RP50EJ

- * Kamera Steuereinheit
- * Kontrolle über Konfiguration und Bildqualität
- * einfache Bedienung
- * bis zu 100 voreingestellte Datenspeicher verfügbar
- * Steuerung bis zu 100 Remote-Kameraeinheiten

M-PAWRP50



Sony OLED Referenzmonitor 17"

- * HD 1080x1080
- * Herausragendes schwarz
- * schnelle Reaktionszeiten
- * keine Bewegungsunschärfe

M-Sony-OLED17



HD Camcorder HCV100

- * Aufzeichnung auf SD
- * Full HD Videos 1920x1080/50p
- * 34x optisches Zoom
- * 42x digital Zoom

M-HDCAM



Canon XM1

- * 3 Chip CCD Bildwandler
- * 20-fach optischer Zoom
- * optischer Bildstabilisator
- * 2 Lux Lichtempfindlichkeit
- * TFT-LCD Farbsucher mit 180.000 Pixel und ein 2,5-Zoll-Display

M-Canon-XM1



VZ9 Wolf Visualizer

M-Wolf-VZ9

- * 16 fach Optischer Zoom
- * High Speed Autofocus
- * Spezielle Arbeitsfläche für Folien
- * Fernbedienung mit Laserpointer
- * HDMI Ausgang 1080p/60



Elmo Dokumenten Kamera

M-Elmo-DK

- * 12 fach Optischer Zoom
- * Kamera Kopf und -Arm 300° drehbar
- * HDMI Ein und Ausgang
- * Full HD 1080p/60



Logitech Group

M-Logi-Group

- * Videokonferenzsystem
- * Kamera 10 fach Zoom
- * Full-Duplex Freisprecheinrichtung
- * USB zum Notebook
- * Optional Erweiterungsmikrofone





Logitech Rally Plus

M-Logi-Rally

- * Konferenz Kamera mit 120° Sichtfeld
- * Auflösungen bis 4K
- * 2 rundstrahlende Mikros
- * optimierte Lautsprecher für kleine Konferenzräume
- * kompakt All in one



Logitech Mikro Rally

M-Mikro_rally

- * passend zu Logitech Rally
- * maximal 7
- *



Logitech MeetUp

M-Logi-MeetUp

- * Konferenz Kamera mit 120° Sichtfeld
- * Auflösungen bis 4K
- * 3 rundstrahlende Mikros
- * optimierte Lautsprecher für kleine Konferenzräume
- * kompakt All in one



Video Stativ M-Video-Stativ

- * Dreibein-Stativ mit Kugelkopf
- * Höhe max. 175cm
- * Traglast max. 5kg



Sachtler / Manfrotto M-VS-Prof

- * Video-Stativ
- * Höhe max. 160cm
- * Traglast max. 5kg



Live Streaming Laptop M-vMixLSL

- * Notebook mit vMix Software
- * SIMULTANEOUS STREAMING, RECORDING, AND OUTPUT
- * SIMULTANEOUS STREAMING, RECORDING, AND OUTPUT
- * AVI, MP4, H264, MPEG-2, WMV, MOV and MXF.
- * Audio Files: MP3 and WAV
- * Web Browser, RTSP, PowerPoint, Photos



Decimator Design converter SDI zu HDMI

- * Konvertiert SDI zu HDMI
- * 3G/HD/SD)-SDI zu NTSC/PAL Composite Down Konverter
- * de-embedded Analog Audio über 2x RCA
- * automatische Erkennung von 3G, HD Oder SD
- * Down-Converted-Composite-Output
- * SD wird unverändert durchgeschliffen



Blackmagic Design Minikonverter SDI zu HDMI

- * Konvertiert SDI zu HDMI
- *
- *



Blackmagic mini Converter HDMI to HDSDI M-BM-HDMI-SDI

- * Konvertiert HDMI in HDSDI
- *



Blackmagic ATEM Mini Pro

- * Live-Produktionsmischer mit Streaming-Funktion
- * Aufzeichnung auf USB
- * Multiviewer Ausgang
- * Greenscreen-Croma-keyer



Blackmagic Television Studio HD

- * Live-Produktionsmischer mit Streaming-Funktion
- * Aufzeichnung auf USB
- * Multiviewer Ausgang
- * Greenscreen-Croma-keyer



Blackmagic Hyperdeck Studio HD Mini

- * kompakter Videorekorder
- * Aufzeichnen von H.264-, ProRes
- *



Blackmagic Designer Web Presenter HD

- * kompakte Komplettlösung für's Streaming
- * direkt an youTube, Facebook, Twitch, Twitter
- * und andere Video-Plattformen zu streamen
- * USB-Anschlüsse funktionieren wie eine Webcam



Blackmagic Design HyperDeck Studio 4K Pro

- * 2G-SDI-Ein- und Ausgänge
- * HDMI-Ein- und Ausgang
- * Aufzeichnung und Wiedergabe von Dateien in H.264/5,
- * 2,2" LC-Display
- * USB-C (bis 5 Gbit/s) für Aufzeichnungen auf externe Laufwerke



AJA KiPro HD Recorder

M-AJAKiProHD

- * Aufzeichnung in ProRes 422
- * 10 Bit Signalverarbeitung 4:4:2 Farbabtastung
- * Up-,Down-und Cross-Konvertierung
- * 24 Bit/48kHz Audio Signalverarbeitung
- * 500 GB Festplatte



AJA - KiPro Go

M-AJAKiProGo

- * HD / SD Solid State Disk Video Recorder
- * Multi-Channel Aufzeichnung von bis zu 4 Streams
- * mit 1080p/50 bzw. 1080p/60
- * Integriertes 720p LCD Display
- * 4:2:0, 4:2:2, 4:4:4 Farbabtastung
- * Codec Support: H.264, MPEG-4





Blackmagic Teranex Express

- * SD / HD / Ultra HD Up/Down Konverter
- * 227 Bidirektionale und gleichzeitige Konvertierung aller SDI-Signale
- * Eingebauter Up-, Down- und Cross-Konverter für Echtzeitkonvertierung
- * 4:2:2 10 Bit Abtastfrequenz
- * LCD Display für Bildschirmmenüs



Blackmagic Design SmartView Duo 2

M-BM7DUO

- * 2x 7" Monitore
- * Video In: 2 xHDSDI mit Loop Out
- * Auflösung: 800 x 480 Pixel
- * SDI-Formatunterstützung 420p/60; 1080p/30; 1080i/60



Lilliput RM-7029S

M-Li7029

- * 2x 7" LCD Monitor
- * Auflösung 1920x1200
- * Anschlüsse Eingabe 3G-SDI, HDMI 2.0, LAN
- * Anschlüsse Ausgabe 3G-SDI, HDMI 2.0





4K 8bit IPS LCD Field-Monitor

12,5 Zoll 4K-Monitor mit HDMI 2.0, 3G-SDI,
4K 3840 x 2160 Pixel Auflösung
4K Displayport / HDMI 2.0 / HDMI 1.4 / 3G-SDI

	Fotograf * mit Bildbearbeitung	auf Anfrage		

	Video Aufnahmen mit Kameramann * Video Aufnahme *	auf Anfrage		

	Video Aufnahmen mit EB - Team * Video Aufnahme * mit EB-Team	auf Anfrage		

	Luftaufnahme mit Drohne * Video Aufnahme mit Drohne	auf Anfrage		

	Video Bearbeitung * mit Apple Final Cut Pro * DVD / USB Erstellung *	auf Anfrage		

*	auf Anfrage		

UHD Produktion



Bild: Hifi Klang Elektronische Medien / Siege Bildnachweise

UHD Kameras

- * Broadcast Kamera UHD
- * mit Studio Optiken 22-fach; 86-fach; 107-fach

auf Anfrage



Bild: Hifi Klang Elektronische Medien / Siege Bildnachweise

Mobile UHD Broadcast Produktion

- * professionelle Filmproduktin
- * von der Konzeption bis zur Endproduktion
Werbefilme; Iagefilme

auf Anfrage



Bild: Hifi Klang Elektronische Medien / Siege Bildnachweise

POSTPRODUKTION

- * Nach einer Veranstaltung ... beginnt die Postproduktion
- * Vom Teaser oder Trailer über Dokumentation
- * Messevideo bis zu Imagefilmen oder Fernsehbeiträgen

auf Anfrage



Bild: Hifi Klang Elektronische Medien / Siege Bildnachweise

DIGITALISIERUNG

- * Auf Wunsch übernehmen wir auch die Verarbeitung,
- * Bearbeitung und Optimierung vorhandener Aufzeichnungen
- * und digitalisieren sie.

auf Anfrage

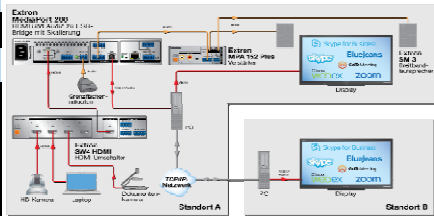

Streaming mit Software Codec

MediaPort 200; Neu MediaPort 300
PTZ Kameras

auf Anfrage

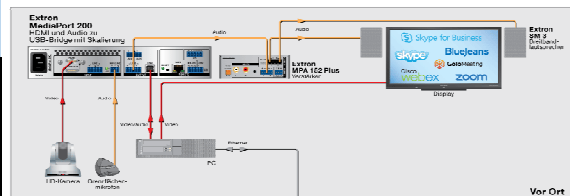

Konferenzraum - Paar

Zwei Niederlassungen nutzen jeweils einen MediaPort 200 für eine optimale Video- und Audioqualität bei internen Videokonferenzsitzungen.

auf Anfrage

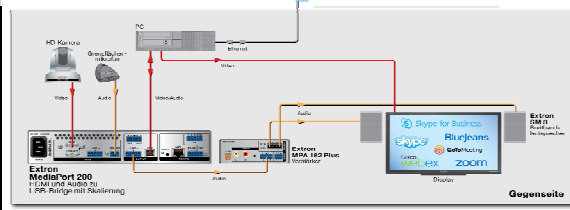



Streaming mit Software Codec

MediaPort 200, MediaPort 300
Dom Kamera

auf Anfrage

Extron Produkte

	MediaPort 200	M-MP200		
	<ul style="list-style-type: none"> * HDMI und Audio zu USB Bridge mit Skalierung * Integriert professionelle AV-Quellen in Software -Codec * Videoskalierung bis 1080p/15 * AEC-Referenzausgang * HDCP-konformer HDMI-Eingang und Durchschliff 			

 	MediaPort 300	4K/60	M-MP300	
	<ul style="list-style-type: none"> * 4K HDMI und Audio zu USB-Bridge mit Skalierung * Integriert professionelle AV-Quellen in Software -Codec * Videoskalierung für eine USB-Ausgabe bis zu 4K/30 * Die Geräteverbindungen bis zu USB 5 Gbps * HDCP-konformer HDMI-Eingang und Durchschliff * USB-Treiber für universelle Kompatibilität 			

	Extron DVS 605 HDSDI		M-DVS605SDI	
	<ul style="list-style-type: none"> * Skalierer mit 5 Eingängen und natloser Umschaltung * Eingänge: 3HDMI und 2 Universal Analoge * Simultane Ausgänge VGA, HDMI und HDSDI * PiP Bild in Bild Modus * Out Auflösung bis 1080p/60 			

	Extron IN 1604HD		M-IN1604HD	
	<ul style="list-style-type: none"> * HDCP-konformer Skalierer mit vier Eingängen * Eingänge: 3 HDMI; 1 VGA * HDMI Ausgang mit Audio Embedding * Audio Out 			

HDMI zu HDMI Skalierer

	DSC HD HD		M-DSCHDHD	
	<ul style="list-style-type: none"> * HDMI zu HDMI Skalierer * 30 Bit Skalierer * HDCP -konform * EDID Minder verwaltet automatisch EDID Kommunikation 			

	IN 1606		M-IN1606	
	<ul style="list-style-type: none"> * HDCP-konformer Skalierer mit vier Eingängen * Eingänge: 4 HDMI; 2 VGA * 2 HDMI Ausgang mit Audio Embedding * Audio Out 			

Skalierer

	DSC 301 HD	M-DSC301HD		
	<ul style="list-style-type: none"> * Kompakter, HDCP-konformer Videoskalierer * Eingänge: Video, VGA, HDMI * Ausgang: HDMI * Auflösungen bis 1920x1200 * HDCP -konform 			

	IN 1806	M-IN1806		
	<ul style="list-style-type: none"> * 4K/60 Präsentationsumschalter * Eingänge: 1 DP, 5 HDMI * Ausgänge: HDI; DTP2 * Umfassendes EDID Management * Nahtlose Umschaltung 			

	DSC 3G-HDA	M-DSC3GHDA		
	<ul style="list-style-type: none"> * 3G-DDI zu HDMI Skalierer mit Audio Embedding * Ausgangsauflösung bis 1920x1200, 1080p/60 und 2k * Kabelkompensation am Eingang * Neutaktung am gepufferten Durchschliff 			

	DSC HD-3G A	M-DSCHD3GA		
	<ul style="list-style-type: none"> * HDMI zu 3G-SDI mit Audio Embedding * 2 Simultane 3G-SDI/HD Ausgänge * Ausgangsauflösung bis 10180p/60 und 2K 			

	RGB-HDMI 300A	M-RGB300A		
	<ul style="list-style-type: none"> * RGB zu HDMI Skalierer * Embedding von HDMI-Audio * Ausgangsaufösungen bis 1920x1200, 1080P/60 2k * EDID Emulation 			

	Annotator 300	M-Annotator300		
	<ul style="list-style-type: none"> * Prozessor zur Einblendung von Zusatzinformationen * Professionelle Skalierung * Auflösungen: 2560x1600 			

	Annotator	M-Annotator		
	<ul style="list-style-type: none"> * Zwei Fenster-Multi-Grafikprozessor * Ausgangsauflösung bis 1920x1200 einschließlich 1080p/60 			

	MGP 462 HD SDI	M-MGP462HDSDI		
	<ul style="list-style-type: none"> * Zwei Fenster-Multi-Grafikprozessor * Ausgangsauflösung bis 1920x1200 einschließlich 1080p/60 * Live Hintergrundbild * Übergangseffekte für Fenster * 			

Streaming Produkte

	Extron SMP351	M-SMP351		
	<ul style="list-style-type: none"> * Live Aufzeichnung und -Streaming * H.264 Codierung * Hochwertige Skalierung mit flexiblem Zwei-Fenster Management * RTMP- und RTMSP-Streamingprotokolle * Erstellt MP4-Medien oder M4A Audiodateien * keine Lizenzgebühren 	80GB Festplatte USB Recording		

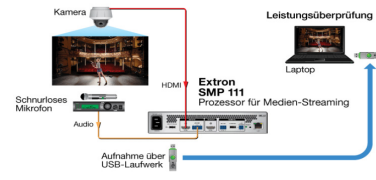
	Extron SMP111	MSMP111		
	<ul style="list-style-type: none"> * Live Aufzeichnung und -Streaming * H.264 Codierung * Hochwertige Skalierung * RTMP Streamingprotokolle * Erstellt MP4-Medien Dateien * keine Lizenzgebühren 			

	Extron SMD 101	M-SMD101		
	<ul style="list-style-type: none"> * H.264 Dekodierer für Medien-Streaming * Kompatibel mit MP4 und MP2 TransportStreamContainerFormaten * Integrierter Skalierer EDID basiert * Texteinblendung * HDMI Ausgang 	1920x1200		

Multi-Fenster-Prozessor

	Extron MGP641	M-MGP641		
	<ul style="list-style-type: none"> * 4K/60 HDMI Multi-Fenster-Prozessor mit DTP2-Extender * Darstellung von bis zu vier Quellenfenstern auf einer einzigen * Bildwand mit statischem oder Live-Hintergrund * Unterstützt HDMI 2.0-Spezifikationen, einschließlich * Datenraten bis zu 18 Gbps, Deep Color bis zu 12 Bit und * verlustfreier HD-Audioformate 			

Webex, Teams, Zoom, GoToMeeting

UCS 900 USB Super Speed USB Extender Set M-UCS900SET

- * Super Speed USB-Glasfaser-Extender 42-298-01
- * Überträgt die Signale von USB-Peripheriegeräten bis zu 150 m
- * 50m Glasfaser Kabel
- *
- *

USB Extender Plus Set M-USB-EX-Plus

- * Twisted Pair-Extender für USB-Peripheriegeräte 60-1471-12
- * Überträgt die Signale von USB-Peripheriegeräten bis zu 100 m 60-1471-13
- * Unterstützt USB 2.0- bis 1.0-Geräte mit Datenraten bis zu 480 Mbps.
- * Kompatibel mit USB 3.0-Geräten
- * 50m CATx Kabel

Extron NAV500SET M-NAV500

- * NAV Pro AV über IP
- * Streamt professionelles Video mit besonders geringer Latenz
- * NAVigator Pro AV über IP-Systemmanager
- * NAV E 501 1G Pro AV über IP-Kodierer - HDMI, Ethernet und USB
- * NAV SD 501 1G Pro AV über IP-Decoder mit Skalierer - HDMI, Ethernet und USB

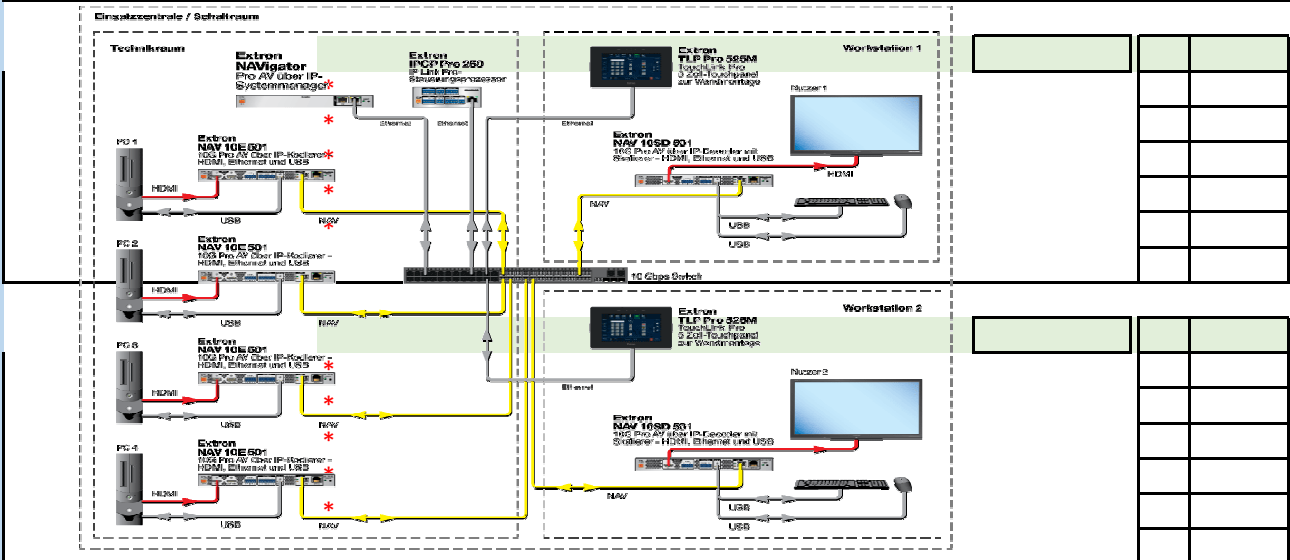

HDMI Verteilerverstärker

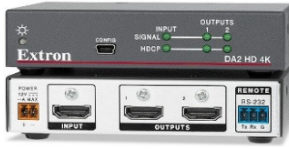

HDMI HD 4K Verteilerverstärker mit 2 Ausgängen

M-DA2HD4K

- * Verteilerverstärker für Auflösungen bis 4K
- * EDID Minder verwaltet automatisch EDID Kommunikation
- * Automatische Kabelkompensation bis 15m
- * Key Minder überprüft kontinuierlich die HDCP-Konformität



HDMI HD 4K Verteilerverstärker mit 4 Ausgängen

M-DA4HD4K

- * Verteilerverstärker für Auflösungen bis 4K
- * EDID Minder verwaltet automatisch EDID Kommunikation
- * Automatische Kabelkompensation bis 15m
- * Key Minder überprüft kontinuierlich die HDCP-Konformität



HDMI HD 4K Verteilerverstärker mit 6 Ausgängen

M-DA6HD4K

- * Verteilerverstärker für Auflösungen bis 4K
- * EDID Minder verwaltet automatisch EDID Kommunikation
- * Automatische Kabelkompensation bis 15m
- * Key Minder überprüft kontinuierlich die HDCP-Konformität

HDMI Umschalter



SW2 HD 4K HDMI Umschalter

M-SW2HD

- * HDMI Umschalter mit 2 Eingängen
- * EDID Minder verwaltet automatisch EDID Kommunikation
- * Datenraten bis zu 10,8Gbps
- * Automatische Kabelkompensation
- * Key Minder überprüft kontinuierlich die HDCP-Konformität



SW4 HD 4K HDMI Umschalter

M-SW4HD

- * HDMI Umschalter mit 2 Eingängen
- * EDID Minder verwaltet automatisch EDID Kommunikation
- * Datenraten bis zu 10,8Gbps
- * Automatische Kabelkompensation
- * Key Minder überprüft kontinuierlich die HDCP-Konformität





SW6 HD 4K HDMI Umschalter

M-SW6HD

- * HDMI Umschalter mit 2 Eingängen
- * EDID Minder verwaltet automatisch EDID Kommunikation
- * Datenraten bis zu 10,8Gbps
- * Automatische Kabelkompensation
- * Key Minder überprüft kontinuierlich die HDCP-Konformität

	HD 4K 101 Plus HDMI Kabelequilizer	M-HD4K101Plus		
	<ul style="list-style-type: none"> * 4K/60 HDMI Kabelequilizer * Computerauflösungen 4k/60 mit 4:4:4 * HDCP 2.2-konform * Automatische Kabelkompensation am Eingang * Key Minder überprüft kontinuierlich die HDCP-Konformität 			

	DXP 44 HD 4K PLUS	M-DXP44		
	<ul style="list-style-type: none"> * HDMI Kreuzschiene 4K/60 4:4:4 * Datenraten bis 18GBps * Key Minder überprüft kontinuierlich die HDCP-Konformität * EDID Minder verwaltet automatisch EDID Kommunikation 			

	DXP 88 HD 4K PLUS	M-DXP88		
	<ul style="list-style-type: none"> * HDMI Kreuzschiene 4K/60 4:4:4 * Datenraten bis 18GBps * Key Minder überprüft kontinuierlich die HDCP-Konformität * EDID Minder verwaltet automatisch EDID Kommunikation 			

Präsentationsmedienumschalter

	MPS 601	M-MPS601		
	<ul style="list-style-type: none"> * Präsentationsmedienumschalter * 2 Analog Universal-Eingänge bis 2K * 3 HDMI Eingänge bis 4K * 1 HDMI Ausgang bis 4k 			

	DTP CrossPoint 84	M-DTPCP84		
	<ul style="list-style-type: none"> * 8x4 Präsentationskreuzschiene * 6 HDMI und 2 DTP Eingänge und 3 Mikro Eingänge * 2 HDMI; 2 DTP ; 4 Audio, 50W Integrierter Verstärker * Integrierter Controller iPCP350M * DSP 			

	USP 407 Analog	M-USP407		
	<ul style="list-style-type: none"> * Universeller Signalprozessor * Integrierter Präsentationsumschalter * Auflösungen bis 1920x1200 bis 1080/p * Live Hintergrundbild * 			

DVI Verteilerverstärker



DVI DA2

M-DVIDA2

- * DVI Verteiler-Verstärker
- * Auflösungen bis 1920x1200
- * EDID Weiterleitung zum lokalen Ausgang
- * Automatische Kabelkompensation bis 30m
- * 5V / 250mA an jedem Ausgang



DVI DA4

M-DVIDA4

- * DVI Verteiler-Verstärker
- * Auflösungen bis 1920x1200
- * EDID Weiterleitung zum lokalen Ausgang
- * Automatische Kabelkompensation bis 30m
- * 5V / 250mA an jedem Ausgang

DVI Umschalter



SW2 DVI

M-P350konf6

- * DVI Umschalter 2 fach
- * Single link DVI-D Umschaltung
- * Auflösungen: 1920x1200 incl. HDTV 1080p/60 2k
- * EDID Minder verwaltet automatisch EDID Kommunikation



DXP 88 DVI Matrix

M-DXP44

- * DVI Matrix 8x8
- * Single link DVI-D Umschaltung
- * Auflösungen: 1920x1200 incl. HDTV 1080p/60 2k
- * EDID Minder verwaltet automatisch EDID Kommunikation

DVI zu ANLOG Interface mit EDID Minder



DVI-RGB200

M-DVIRGB200

- * Wandelt Single Link DVI-D in analoges RGB Video um
- * EDID Minder verwaltet automatisch EDID Kommunikation
- * Auflösungen: 1920x1200 incl. HDTV 1080p/60 2k
- * DDC Weiterleitung



USP 405 Analog

M-USP405

- * Universal Signal Prozessor
- * All in one Scaler, Scan converter, Transcoder
- * bis 720p
- * Format converter

Displayport Verteilerverstärker



DP DA2 Displayport Verteilerverstärker

M-DPDA2

- * Verteilerverstärker für Auflösungen bis 2550x1600/60
- * EDID Minder verwaltet automatisch EDID Kommunikation
- * DisplayPort Datenraten bis zu 10,8Gbps
- * Key Minder überprüft kontinuierlich die HDCP-Konformität

DisplayPort Umschalter



SW2 DP

M-SW2DP

- * DisplayPort Umschalter mit 2 Eingängen
- * EDID Minder verwaltet automatisch EDID Kommunikation
- * Auflösungen: 2500x1600 incl. HDTV 1080p/60 2k
- * DisplayPort Datenraten bis zu 10,8Gbps
- * Key Minder überprüft kontinuierlich die HDCP-Konformität

HDSDI / SDI Extender



3G HD-SDI 101

M3GHSDI

- * Kabel-Equiliser für 3G SDI
- * Automatische Anpassung an digitale SMPTE-und ITU-Video
- * SDI bis 150m mit RG6
- * HD-SDI bis 120m mit RG6
- * Automatische Neutaktung am Ausgang

HDSDI / SDI Verteilerverstärker



MDA 4V HD-SDI

M-MDA4VHSDI

- * Verteilerverstärker mit 4 Ausgängen
- * Datenraten bis 2,97Gbps
- * Automatische Kompensation am Eingang
- * Automatische Neutaktung am Ausgang



DA4 12G HD-SDI

M-DA4HSD12G

- * Verteilerverstärker mit 4 Ausgängen
- * Datenraten bis 11,88Gbps
- * Automatische Kompensation am Eingang
- * Automatische Neutaktung am Ausgang



PIP444

Analog

M-PIP444

- * PiP Processor
- * Four Video Windows
- * Konfigurierbarer Hintergrund und Rahmenfarben
- * Überblendung, Wisch oder einfacher Schnitt
- *

De-Embedder für HDMI -Audio



HAE 100 4K

M-HAE100

- * De-Embedding von HDMI-Audio
- * Analog Stereo und S/PDIF-Audioausgängen
- * Videoauflösungen bis 4K

Scan Converter



VSC 500

M-VSC500

- * Scan Konverter von hochauflösenden Computer- zu Videosignal
- * Computerauflösungen bis 1920x1200
- * Vertikale Filter
- * Zoomsteuerung
- * Ausgang: Video, S-Video, Component

Drahtlos HDMI Extender



eLink 100

M-eLink100

- * Professioneller Funk Extender für HDMI
- * bis 30m
- * HDCP konform
- * Professionelle Technologie von einem Sender bis zu 4 Empfänger
- * HDTV 1080p/60

Glasfaser Extender



FOXBOX Tx HDMI

M-FOXBOXTxHDMI

- * Glasfaser-Sender für HDMI,Audio und RS232
- * HDCP -konform
- * bis 1920x1200 HDTV 1080p/60
- * Key Minder überprüft kontinuierlich die HDCP-Konformität
- * EDID Minder verwaltet automatisch EDID Kommunikation



FOXBOX Rx HDMI

M-DVIDA4

- * Glasfaser-Empfänger für HDMI,Audio und RS232
- * HDCP -konform
- * bis 1920x1200 HDTV 1080p/60
- * Key Minder überprüft kontinuierlich die HDCP-Konformität
- * EDID Minder verwaltet automatisch EDID Kommunikation



DVI104

MDVI104

- * DVI-Glasfaser Extender
- * Übertägt Single Link DVI-D bis 500m über 4 Glasfaser MM
- * bis 1920x1200 einschließlich 1080p/60 und 2K
- * Sender wird vom DVI Ausgang mit Strom versorgt
- * Video Isolator

DTP Systems

DTP Sender



DTP HDMI 4K 330Tx

M-DTPHDMI230Tx

- * DTP Sender für HDMI
- * HDCP 2.2 konform
- * Unterstützt Datenraten bis 10,2Gbps
- * EDID Minder verwaltet automatisch EDID Kommunikation
- * für eine optimale Leistung wird ausdrücklich XTP DTP 24 Twisted Pair Kabel empfohlen

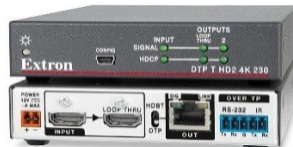

DTP T HD2 4K 230

M-DTPTHD24K230

- * DTP Sender für HDMI
- * HDCP 2.2 konform
- * Unterstützt Datenraten bis 10,2Gbps
- * EDID Minder verwaltet automatisch EDID Kommunikation
- * für eine optimale Leistung wird ausdrücklich XTP DTP 24 Twisted Pair Kabel empfohlen

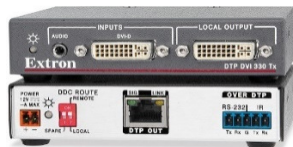

DTP DVI 4K 330Tx

M-DTPDVI330Tx

- * DTP Sender für DVI
- * Unterstützt HDMI Signale
- * Unterstützt Datenraten bis 10,2Gbps
- * EDID Minder verwaltet automatisch EDID Kommunikation
- * für eine optimale Leistung wird ausdrücklich XTP DTP 24 Twisted Pair Kabel empfohlen

DTP Empfänger



DTP HDMI 4K 230Rx

M-DTPHDMI230Rx

- * DTP Empfänger für HDMI
- * HDCP 2.2 konform
- * Unterstützt Datenraten bis 10,2Gbps
- * EDID Minder verwaltet automatisch EDID Kommunikation
- * für eine optimale Leistung wird ausdrücklich XTP DTP 24 Twisted Pair Kabel empfohlen



DTP DVI 4K 230Rx

M-DTPDVI230Rx

- * DTP Empfänger für DVI
- * HDCP 2.2 konform
- * Unterstützt Datenraten bis 10,2Gbps
- * EDID Minder verwaltet automatisch EDID Kommunikation
- * für eine optimale Leistung wird ausdrücklich XTP DTP 24 Twisted Pair Kabel empfohlen

Twisted Pair VGA



VTT001 und VTR001 SET

M-VTT-VTR001

- * Übertragung von VGA Signalen über CAT 90m
- * CAT5; CAT5e; CAT6
- * Fernstromversorgung
- *
- *



MTP T 15HDA M-MTP15HD

- * Übertragung von VGA Signalen über CAT 185m
- * CAT5; CAT5e; CAT6
- * Peaking und Gain
- * Gepufferter MTP Ausgang



MTP DA8 M-MTPDA8

- * MTP Verteilerverstärker
- * Teilt und puffert eingehende Signale von einem Twisted Pair-Sender
- * Kompatibel mit allen Produkten der Extron MTP- und VT-Serie
- * Unterstützt RGBHV, RGBS, RGSB, FBAS-Video

Grafik Umschalter



SGS 408 M-SGS408

- * Grafikumschalter mit 8 Eingängen
- * Nahtloses Umschalten
- * Auflösung bis 1400x1050 bis HDTV 1080p/60
- * DVI Ausgang
- * Vorschau und Programmausgänge



ISS 506 M-ISS506

- * Grafikumschalter mit 6 Eingängen
- * Nahtloses Umschalten
- * Auflösung bis 1400x1050 bis HDTV 1080p/60
- * SDI Eingang DVI Ausgang
- * Vorschau und Programmausgänge



PA 300 M-PA300

- * RGBHV Analog Verstärker
- * Eingang und Ausgag 5 BNC



CrossPoint 84 M-CP84

- * 8 x 4 Matrix
- * RGBHV
- * 8 Eingänge
- * 4 Ausgänge
- *

AV Technik

VGA Verteilerverstärker



P2DA2 PLUS

- * Verteilerverstärker VGA mit 2 Ausgängen
- * Bandbreite 300MHz

M-P2DA2



P2DA2xi

- * Verteilerverstärker VGA mit 2 Ausgängen
- * Bandbreite 350MHz
- * Verstärkung und Peaking einstellbar

M-P2DA2xi



P2DA4xi

- * Verteilerverstärker VGA mit 4 Ausgängen
- * Bandbreite 350MHz
- * Verstärkung einstellbar

M-P2DA4xi



P2DA6xi

- * Verteilerverstärker VGA mit 6 Ausgängen
- * Bandbreite 350MHz
- * Verstärkung einstellbar

M-P2DA4xi

VGA Umschalter



SW2 VGA

- * Umschalter für VGA und Audio
- * Bandbreite 300MHz

M-SW2VGA



SW4 VGA

- * Umschalter für VGA und Audio
- * Bandbreite 300MHz
- *
- *
- *

M-SW4VGA



VSV 2VGA A

M-VSV2VGA

- * VGA Umschalter mit 2 Eingängen
- * Bandbreite 300MHz
- * Gepufferter Durchschleifeingang 1



SW2 VGA DA2 Umschalter

M-SW2DA2VGA

- * Umschalter für VGA mit 2 Eingängen und 2 Ausgängen
- * Bandbreite 300MHz
- * Jeder Ausgang einzeln gepuffert

VGA Kreuzschienen



MVX 44VGA

M-MVX44VGA

- * VGA Matrix 4x4
- * Ultra Breitband



MVX 88VGA

M-MVX88VGA

- * VGA Matrix 8x8
- * Ultra Breitband



RGB 201Rxi

M-RGB201

- * Universal VGA Interface
- * Eingang VGA
- * Ausgang BNC
- * H und V Shift
- * Gain und Peak



RGB 203Rxi

M-RGB203

- * Universal VGA Interface mit 3 Eingängen
- * Eingang VGA
- * Ausgang BNC
- * H und V Shift
- * Gain und Peak



DMP 64 PLUS

M-DMP64PLUS

- * Digitale 6x4 Matrix DSP
- * 6 Accoustic Echo Cancellation
- * Konfigurierbare USB Audioschnittstelle
- *



DMP 128 C

M-DMP128C

- * Digitale 12x8 Matrix DSP
- * 8 Acoustic Echo Cancellation
- * Konfigurierbare USB Audioschnittstelle
- * Player integriert



XPA 4002

M-XPA4002

- * Verstärker 2x 400W
- * Lüfterlose Kühlung

Steuerungssysteme



TLP Prp 525

M-TLP525

- * Frei programmierbare Oberfläche
- * PoE
- * Eingebauter Lautsprecher
- *



TLP Pro 1020

M-TLP1020

- * Frei programmierbare Oberfläche
- * PoE
- * Eingebauter Lautsprecher



IPCP Pro Steuerungsprozessor

M-IPCP350

- * 3x Serial
- * 4x Digital I/O
- * 2x IR/ Serial
- * 4x Relays
- * 1x eBus
- * 3x LAN

FBAS Video



MDA 3 AV Dual

- * Verteilt FBAS Signale an BNC Buchsen

M-MDA3AVDual



MDA 5 AV

- * Verteilt FBAS Signale an BNC Buchsen

M-MDA5AV



DA 12V/6V

- * Verteilt FBAS Signale an BNC Buchsen

M-DA6Dual



MDA 5A RCA

- * Verteilt unsymmetrische Audio Signale
- *

M-MDA5ARCA



MSW 4V rs

- * FBAS Umschalter mit 4 Eingängen

M-DVIDA4





VTG 400

- * Programmierbarer Testbid Generator
- * 34 Video Testbilder
- * 7 Audio Signale
- * 101 auswählbare Auflösungen
- * Skope Triggerung

M-VTG400

Extron Glasfaser Kabel

	HD Pro Plenum Glasfaser	15m	M-HDMI-15G		
	* Flexibles ultradünnes HDMI Kabel	22m	M-HDMI-22G		
	* Farbig gekennzeichnete Enden				
	* Es wird keine externe Stromversorgung benötigt				
	* aktives Glasfaserkabel für Auflösungen bis 4K				

	HD Pro Plenum Glasfaser	30m	M-HDMI-30G		
	* Flexibles ultradünnes HDMI Kabel	45m	M-HDMI-45G		
	* Es wird keine externe Stromversorgung benötigt				
	* Farbig gekennzeichnete Enden				
	* aktives Glasfaserkabel für Auflösungen bis 4K				







	HD Pro Plenum Glasfaser	53m	M-HDMI-53G		
	* Flexibles ultradünnes HDMI Kabel	60m	M-HDMI-60G		
	* Farbig gekennzeichnete Enden				
	* Es wird keine externe Stromversorgung benötigt				
	* aktives Glasfaserkabel für Auflösungen bis 4K				







	HD Pro Plenum Glasfaser	75m	M-HDMI-75G		
	* Flexibles ultradünnes HDMI Kabel	91m	M-HDMI-91G		
	* Farbig gekennzeichnete Enden				
	* Es wird keine externe Stromversorgung benötigt				
	* aktives Glasfaserkabel für Auflösungen bis 4K				





HDMI 4K/60 Zertifiziert







	HDMI ULTRA	1,8m	M-HDMI-018U		
	* Flexibles ultradünnes HDMI Kabel	2,7m	M-HDMI-027U		
	* 4k 60 Zertifiziert				

	HDMI ULTRA	3,6m	M-HDMI-36U		
	* Flexibles ultradünnes HDMI Kabel	4,5m	M-HDMI-45U		
	* 4k 60 Zertifiziert				

Extron RG6 Kabel				
	RG6 BNC Kabel	1,8m	M-RG6-018	
	* für sehr hohe Auflösungen * BNC zu BNC Stecker	3,6m	M-RG6-036	
	RG6 BNC Kabel	10m	M-RG6-10	
	* für sehr hohe Auflösungen * BNC zu BNC Stecker	20m	M-RG6-20	
	RG6 BNC Kabel	30m	M-RG6-30	
	* für sehr hohe Auflösungen * BNC zu BNC Stecker	40m	M-RG6-40	
	RG6 BNC Kabel	50m	M-RG6-50	
	* für sehr hohe Auflösungen * BNC zu BNC Stecker	75m	M-RG6-75	
Extron XTP DTP 24 Kabel				
	XTP DTP 24 Kabel	10m	M-XTP24-10	
	* für Produkte der DTP / XTP Serie	15m	M-XTP24-15	
	* Bandbreite bis 475 MHz bis 100m * SF/UTP Design	22m	M-XTP24-22	
	XTP DTP 24 Kabel	30m	M-XTP24-30	
	* für Produkte der DTP / XTP Serie	46m	M-XTP24-45	
	* Bandbreite bis 475 MHz bis 100m * SF/UTP Design	53m	M-XTP24-53	
	XTP DTP 24 Kabel	61m	M-XTP24-61	
	* für Produkte der DTP / XTP Serie * Bandbreite bis 475 MHz bis 100m * SF/UTP Design	91m	M-XTP24-91	

	VGA Micro Kabel	26-567-01	0,9m	M-VGA-009M		
	<ul style="list-style-type: none"> * Dünne flexible Kabel * hohe Bandbreite * 15 Pol HD Stecker auf 15 Pol HD Stecker 	26-567-02	1,8m	M-VGA-018M		
	VGA Micro Kabel	26-567-03	3,6m	M-VGA-036M		
	<ul style="list-style-type: none"> * Dünne flexible Kabel * hohe Bandbreite 15 Pol HD Stecker auf 15 Pol HD Stecker 	26-567-04	7,6m	M-VGA-076M		
	VGA Kabel	26-238-17	10m	M-VGA-10M		
	<ul style="list-style-type: none"> * flexible Kabel * hohe Bandbreite 15 Pol HD Stecker auf 15 Pol HD Stecker 	26-238-18	15m	M-VGA-15M		
	VGA Kabel	26-238-19	22m	M-VGA-22M		
	<ul style="list-style-type: none"> * flexible Kabel * hohe Bandbreite 15 Pol HD Stecker auf 15 Pol HD Stecker 	26-238-20	30m	M-VGA-30M		
	SYM BNC F Kabel	26-531-01		M-SYM-BNCF		
	<ul style="list-style-type: none"> * Mini BNC Kabel für hohe Auflösungen * 15 Pin HD Stecker auf BNC Kupplung 					
	SYM BNCM	26-533-01		M-SYM-BNCM015		
	<ul style="list-style-type: none"> * Mini BNC Kabel für hohe Auflösungen * 15 Pin HD Stecker auf BNC Stecker * * * 	26-533-11		M-SYM-BNCM030		
	SYM BNCM	26-533-12		M-SYM-BNCM090		
	<ul style="list-style-type: none"> * Mini BNC Kabel für hohe Auflösungen * 15 Pin HD Stecker auf BNC Stecker * * * 	26-533-02		M-SYM-BNCM180		

	<p>SYM BNCM</p> <ul style="list-style-type: none"> * Mini BNC Kabel für hohe Auflösungen * 15 Pin HD Stecker auf BNC Stecker * * * 	<p>M-SYM-BNCM360 26-533-03 M-SYM-BNCM760 26-533-04</p>	<table border="1"> <tr><td></td><td></td></tr> <tr><td></td><td></td></tr> <tr><td></td><td></td></tr> <tr><td></td><td></td></tr> </table>								
	<p>SYM BNCM</p> <ul style="list-style-type: none"> * Mini BNC Kabel für hohe Auflösungen * 15 Pin HD Stecker auf BNC Stecker * * * 	<p>M-SYM-BNCM152 26-53-05 M-SYM-BNCM152 26-533-06</p>	<table border="1"> <tr><td></td><td></td></tr> <tr><td></td><td></td></tr> <tr><td></td><td></td></tr> <tr><td></td><td></td></tr> </table>								
	<p>MHR 5 BNC Kabel</p> <ul style="list-style-type: none"> * Mini BNC Kabel für hohe Auflösungen * BNC Stecker auf BNC Stecker 	<p>1,8m 3,6m M-BNCBNC180 M-BNCBNC360</p>	<table border="1"> <tr><td></td><td></td></tr> <tr><td></td><td></td></tr> <tr><td></td><td></td></tr> <tr><td></td><td></td></tr> </table>								
	<p>MHR 5 BNC Kabel</p> <ul style="list-style-type: none"> * Mini BNC Kabel für hohe Auflösungen * BNC Stecker auf BNC Stecker 	<p>1m 1,5m M-BNCBNC100 M-BNCBNC150</p>	<table border="1"> <tr><td></td><td></td></tr> <tr><td></td><td></td></tr> <tr><td></td><td></td></tr> <tr><td></td><td></td></tr> </table>								
	<p>MHR 5 BNC Kabel</p> <ul style="list-style-type: none"> * Mini BNC Kabel für hohe Auflösungen * BNC Stecker auf BNC Stecker 	<p>2m 3m M-BNCBNC220 M-BNCBNC300</p>	<table border="1"> <tr><td></td><td></td></tr> <tr><td></td><td></td></tr> <tr><td></td><td></td></tr> <tr><td></td><td></td></tr> </table>								
	<p>DPM-HDF / 0,54K PLUS</p> <ul style="list-style-type: none"> * DisplayPort auf HDMI Kupplung * Aktive Konvertierung * Auflösungen 4K/60 4:4:4 bis 18Gbps 	<p>M-DP-HDMI 26-716-01</p>	<table border="1"> <tr><td></td><td></td></tr> <tr><td></td><td></td></tr> <tr><td></td><td></td></tr> <tr><td></td><td></td></tr> </table>								
	<p>HDMIF-DVIDM</p> <ul style="list-style-type: none"> * DVI Stecker auf HDMI Kupplung * bis 1920x1200 1080P/60 * * * 	<p>M-DVI-HDMI 26-616-01</p>	<table border="1"> <tr><td></td><td></td></tr> <tr><td></td><td></td></tr> <tr><td></td><td></td></tr> <tr><td></td><td></td></tr> </table>								

	<p>MDP-DVID * Leitet die EDID Information weiter</p>	<p>M-MDP-DVID 26-673-06</p>	<table border="1"> <tr><td></td><td></td></tr> <tr><td></td><td></td></tr> <tr><td></td><td></td></tr> <tr><td></td><td></td></tr> <tr><td></td><td></td></tr> </table>										
	<p>MDP-DP * Leitet die EDID Information weiter</p>	<p>M-MDP-DP 26-675-06</p>	<table border="1"> <tr><td></td><td></td></tr> <tr><td></td><td></td></tr> <tr><td></td><td></td></tr> <tr><td></td><td></td></tr> <tr><td></td><td></td></tr> </table>										
	<p>MDP-HDMIIF * Leitet die EDID Information weiter</p>	<p>M-MDP-HDMIIF 26-679-06</p>	<table border="1"> <tr><td></td><td></td></tr> <tr><td></td><td></td></tr> <tr><td></td><td></td></tr> <tr><td></td><td></td></tr> <tr><td></td><td></td></tr> </table>										
	<p>USBC - HD * USBC auf HDMI Adapterkabel</p>	<p>M-USBCHD 26-720-01</p>	<table border="1"> <tr><td></td><td></td></tr> <tr><td></td><td></td></tr> <tr><td></td><td></td></tr> <tr><td></td><td></td></tr> <tr><td></td><td></td></tr> </table>										
	<p>USBC - HD * USBC auf HDMI Adapterkabel</p>	<p>M-USBCHD 26-720-06</p>	<table border="1"> <tr><td></td><td></td></tr> <tr><td></td><td></td></tr> <tr><td></td><td></td></tr> <tr><td></td><td></td></tr> <tr><td></td><td></td></tr> </table>										
	<p>USBC - DP * USBC auf Display-Port Adapterkabel</p>	<p>M-USBCDPF 26-719-01</p>	<table border="1"> <tr><td></td><td></td></tr> <tr><td></td><td></td></tr> <tr><td></td><td></td></tr> <tr><td></td><td></td></tr> <tr><td></td><td></td></tr> </table>										
	<p>USBC - DP * USBC auf Display-Port Adapterkabel * * * *</p>	<p>M-USBCDPM 26-719-06</p>	<table border="1"> <tr><td></td><td></td></tr> <tr><td></td><td></td></tr> <tr><td></td><td></td></tr> <tr><td></td><td></td></tr> <tr><td></td><td></td></tr> </table>										

Zubehör



GLI 2000 5BNC

- * Erdungsschleifen-Unterdrücker
- * Mobilität und einfache Handhabung
- * serienmäßig mit Schutzbügeln

M-GLI2000-5BNC

60-601-01



GLI 2000 2BNC

- * Erdungsschleifen-Unterdrücker
- * Mobilität und einfache Handhabung
- * serienmäßig mit Schutzbügeln

M-GLI2000-2BNC

60-603-01

NAV Pro AV über IP

Äußerst geringe Latenz



Navigator

- * Pro AV über IP-Systemmanager
- * Verwaltet, konfiguriert und steuert sicher NAV®
- * Pro AV über IP-Systeme
- * Basisversion für 16 Endpunkte
- * Sicher verschlüsselte Kommunikation zwischen allen Endpunkten

M-NAVigator

60-1525-00



NAV E501 1G HDMI-Kodierer

- * 1G Pro AV über IP-Kodierer - HDMI und USB
- * Kodiert und streamt Video- und Audio-Signale über 1 Gbps-Ethernet
- * PURE3 Intelligent Selective Streaming
- * Hochqualitatives Video mit äußerst geringer Latenz

M-NAVE501

60-1525-12





NAV SD501

- * 1G Pro AV über IP-Decoder mit Skalierer - HDMI, Ethernet und USB
- * PURE3 Intelligent Selective Streaming

M-NAVSD501

60-1525-01





NAV Pro AV über IP-Video

Ursprüngliches Quellenvideo

STUDIOSOUND FÜR JEDES MEETING

Hochwertiges Audio von Shure bringt Klarheit in Konferenzen.



MXCW640

MXCW640 Drahtlose Konferenzsprechstelle



Microflex Complete Wireless

Digitales Konferenzsystem

Microflex Complete Wireless bietet Ihnen die Shure typische Zuverlässigkeit für bis zu 125 Sprechstellen und 8 Dolmetscherkanäle bei externen Meetings, in Räumen mit flexibler Sitzordnung oder in historischen Gebäuden.

Die drahtlose Konferenzsprechstelle MXCW640 kombiniert Mikrofon, Lautsprecher und Touchscreen in einer integrierten, portablen Einheit als optimale Ergänzung für jeden Sitzungsraum. Die Drahtlostechnik macht das Bohren von Löchern und Verkabelungsarbeiten überflüssig, sodass das System schnell für Besprechungen in Räumen mit flexibler Sitzordnung auf- und wieder abgebaut werden kann. Der intelligente Lithium-Ionen-Akku (im Lieferumfang enthalten) bietet über 11 Stunden Laufzeit, eine Auswahl an Schwanenhalsmikrofonen gewährleistet eine hervorragende Sprachabnahme.

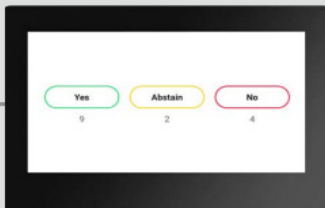
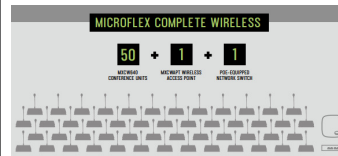

INTEGRATED TOUCHSCREEN VOTING



VIEW VOTING RESULTS ON SCREENS

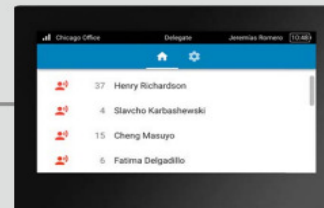

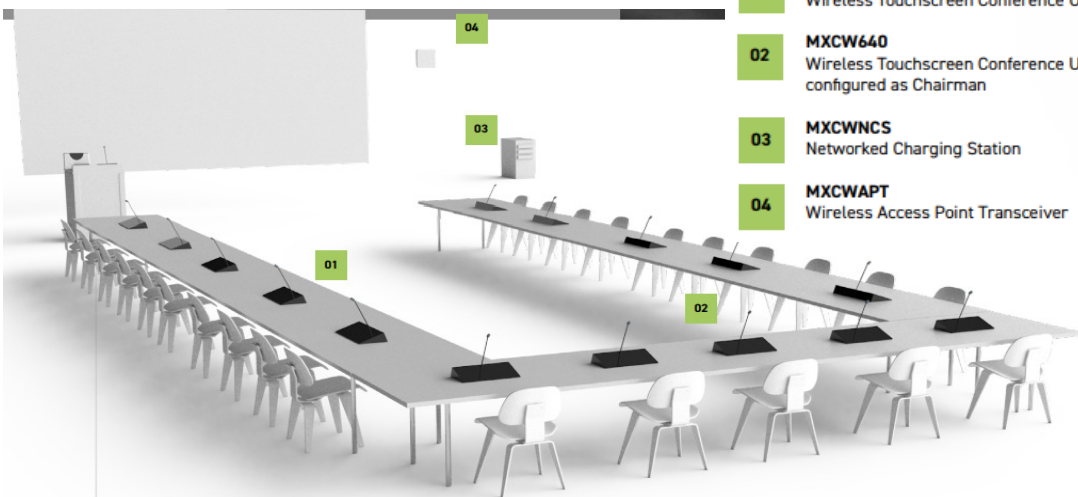

SPEAKER LIST FOR REAL TIME MEETING MANAGEMENT







- 01** **MXCW640**
Wireless Touchscreen Conference Unit
- 02** **MXCW640**
Wireless Touchscreen Conference Unit configured as Chairman
- 03** **MXCWNCs**
Networked Charging Station
- 04** **MXCWAPT**
Wireless Access Point Transceiver



Audio



Shure



 	Shure AD4DE-A	M-SAD4D		
	<ul style="list-style-type: none"> * AD digital Doppelpfänger 470-636 MHz * Quard diversity für größere Reichweite * Transparenter Sound * Kompatibel mit Axient Digital Funksystem * Axient Digital 			

 	Shure AD4QE-A	M-SADQ		
	<ul style="list-style-type: none"> * AD digital Quard-Empfänger 470-636 MHz * Quard diversity für größere Reichweite * Transparenter Sound * Kompatibel mit Axient Digital Funksystem * Axient Digital 			

	Shure AD1-G56	M-SAD1		
	<ul style="list-style-type: none"> * ADX Taschensender 470-636 MHz * Kompatibel mit Axient Digital Funksystem * Verschlüsselte sichere Übertragung * Axient Digital 			

	Shure ADX1M-G56	M-sADX1M		
	<ul style="list-style-type: none"> * ADX Micro Taschensender B87C 470-636 MHz * Kompatibel mit Axient Digital Funksystem * Verschlüsselte sichere Übertragung * Axient Digital 			

	Shure AD2/B87C-G56	Axient Digital	M-SAD2	
	<ul style="list-style-type: none"> * ADX Handsender B87C 470-636 MHz * Kompatibel mit Axient Digital Funksystem * Verschlüsselte sichere Übertragung * Axient Digital 			

	Shure SBC840M-E		M-SSBC840	
	<ul style="list-style-type: none"> * Ethernet Charger for 8 SB910M * * * * 			

DPA



DPA D:FINE Headset

M-DPA-HS2

- * Ein oder Zwei Ohr Head Set
- * höchster Tragekomfort
- * höchste Klangqualität
- * Farbe: beige



DPA 4066

M-DPA-HS2

- * Zwei Ohr Head Set
- * Verstellbarer Nackenbügel
- * links oder rechts Benutzung
- * Farbe: beige



DPA Professionelles Lavaliermikrofon

M-DPA-KRA

- * Nierencharakteristik
- * + 4 dB Präsenzanhebung bei 15 KHz
- * vormontierter Pop-Filter
- * integrierter Schockabsorber



Sennheiser Wireless Digital

M-SEWD

- * größeren Dynamikbereich
- * System automatisch innerhalb von Sekunden die beste Sendefrequenz
- * gleichzeitig bis zu 90 weitere Kanäle dank 56 Mhz Schaltbandbreite
- * Digitales Funksystem ohne Rauschen
- * Lithium-Ionen-Akkupack für bis zu 12 Stunden Betriebsdauer
- * 34 dB Dynamikbereich des Senders



Sennheiser Hand Sender mit Empfänger

M-

- * | Robustes All-in-One Funksystem
- * Drahtloser Taschensender
- * ME2 Lavalier Mikro
- * Verbindungskabel
- * Empfänger Serie 100





Sennheiser Taschensender mit Empfänger

M-

- * | Robustes All-in-One Funksystem
- * Drahtloser Taschensender
- * ME4 Lavalier Mikro
- * Verbindungskabel
- * Empfänger Serie 100

	Sennheiser Taschensender mit Empfänger	M-			
	<ul style="list-style-type: none"> * Robustes All-in-One Funksystem * Drahtloser Taschensender * ME3 Kopfmikrofon * Verbindungskabel * Empfänger Serie 100 				

	IN EAR Sennheiser	M-INEAR			
	<ul style="list-style-type: none"> * Robustes All-in-One Funksystem * Drahtloser Sender * Kopfhörer * Verbindungskabel * Empfänger Serie 100 				



	Sennheiser HSP 4	M-			
	<ul style="list-style-type: none"> * Hochwertiges Kondensator Nackenbügelmikrofon * Nierencharakteristik 				

Tisch Mikrofone

	MX418 Rednerpult Mikro Shure	M-RPM-418			
	<ul style="list-style-type: none"> * Tisch-Kondensator Mikrofon * Nierencharakteristik * Schlanker Schwanenhals 45cm * Taster zum Stummschalten 				



	ME-36 Rednerpult Mikro Sennheiser	M-ME36			
	<ul style="list-style-type: none"> * Hohe Rückkopplungssicherheit * Super Nierencharakteristik * Gleichbleibende Klangqualität auch bei seitlicher Einsprache 				

	MX393 Grezflächen Mikrofon	M-MX393			
	<ul style="list-style-type: none"> * Hohe Rückkopplungssicherheit * halbe Nierencharakteristik * Status LED 				

 	Shure AD4	M-SH-AD4		
	<ul style="list-style-type: none"> * AD4Q digitaler 4-Kanal-Funkempfänger * Quadiversity-Modus für größere Reichweite * Große Schaltbandbreite von bis zu 184 MHz * Netzwerkbasierte Steuerung mit Wireless Workbench® * Kanalqualität-Anzeige gibt Auskunft über HF Signal-Rausch-Abstand 			







	Line 6 Set-2	M-Line6-Set-2		
	<ul style="list-style-type: none"> * Dynamischer Handsender mit Nierenkapsel * Taschensender mit Kondensator Lavaliermikrofon * Head Set * 2 Empfänger * im Case komplett verkabelt 			

	Line 6 Hand	M-Line6-Hand		
	<ul style="list-style-type: none"> * 2,4 GHz Vocal Drahtlossystem (weltweit gebührenfrei nutzbar) * Dynamischer Handsender mit Nierenkapsel * 6 schaltbare Frequenzen (alle 6 auch simultan) * Tisch-Empfänger * XLR- und Klinken-Ausgang 			

 	DPA Adapter	M-DPA-SeA		
	<ul style="list-style-type: none"> * für Sennheiser EW-Serie 			

	Shure Adapter zu DPA Headset	M-DPA-ShA		
	<ul style="list-style-type: none"> * Mini XLR * Passend zu Axient Digital * Passend zu Line 6 * Passend für Shure 			

	Aktive UHF -Richtantenne	M-SUA870		
	<ul style="list-style-type: none"> * Aktive logarithmische periodische Richtantenne * Aktiver HF Booster * Gewinn 7 dB * Wellenwiderstand 50 Ohm 			

	<p>Catch Box Pro Wurfmikrofon</p> <ul style="list-style-type: none"> * Schaumstoffwürfel zum Herumwerfen im Publikum * Farben: Blau, Grün, Orange 	<p>M-Catch</p>	<table border="1"> <tr><td></td><td></td></tr> <tr><td></td><td></td></tr> <tr><td></td><td></td></tr> <tr><td></td><td></td></tr> <tr><td></td><td></td></tr> </table>										
	<p>MS-100 Tischstativ</p> <ul style="list-style-type: none"> * Mikrofon Tischstativ * Metallguss-Standfuß * Trittschallgedämft * Variabler Ausleger 	<p>M-MMS100</p>	<table border="1"> <tr><td></td><td></td></tr> <tr><td></td><td></td></tr> <tr><td></td><td></td></tr> <tr><td></td><td></td></tr> <tr><td></td><td></td></tr> </table>										
	<p>MS-22 Tischstativ</p> <ul style="list-style-type: none"> * Mikrofon Tischstativ * Metallguss-Standfuß * Trittschallgedämft 	<p>M-MMS22</p>	<table border="1"> <tr><td></td><td></td></tr> <tr><td></td><td></td></tr> <tr><td></td><td></td></tr> <tr><td></td><td></td></tr> <tr><td></td><td></td></tr> </table>										
	<p>Einhand Mikrofonstativ</p> <ul style="list-style-type: none"> * Höhenverstellung durch das Einhandsystem * Umlaufender Gummiring im Sockel * Unverlierbare Rändelschraube 	<p>M-EH-Stativ</p>	<table border="1"> <tr><td></td><td></td></tr> <tr><td></td><td></td></tr> <tr><td></td><td></td></tr> <tr><td></td><td></td></tr> <tr><td></td><td></td></tr> </table>										
	<p>Mikrofon Stativ</p> <ul style="list-style-type: none"> * Mikrofon Stativ mit Schwenkarm * Arretierung mit handlicher Flügelmutter * Umklappbare Metallfüße 	<p>M-MicStativ</p>	<table border="1"> <tr><td></td><td></td></tr> <tr><td></td><td></td></tr> <tr><td></td><td></td></tr> <tr><td></td><td></td></tr> <tr><td></td><td></td></tr> </table>										
	<p>Shure Drum Kit</p> <ul style="list-style-type: none"> * 1x PGA52 Bass Drum Mikrofon * 2x PGA56 Snare/Tom Mikrofon * 1x PGA57 Snare Mikrofon * 2x PGA81 Overheadmikrofon 	<p>M-MikDrum</p>	<table border="1"> <tr><td></td><td></td></tr> <tr><td></td><td></td></tr> <tr><td></td><td></td></tr> <tr><td></td><td></td></tr> <tr><td></td><td></td></tr> </table>										
	<p>Mikrofon Kissen</p> <ul style="list-style-type: none"> * Mikrofon Ablagekissen * Verhindert Geräusche beim Ablegen von Handsendern * Das Mikrofon kann nicht mehr rollen 	<p>M-MikKissen</p>	<table border="1"> <tr><td></td><td></td></tr> <tr><td></td><td></td></tr> <tr><td></td><td></td></tr> <tr><td></td><td></td></tr> <tr><td></td><td></td></tr> </table>										

Mischpulte



Soundcraft Vi1 Digitales Mischpult

M-Vi1

- * Digitalmischpult mit 32 Mic/Line Eingängen
- * redundante PSU
- * 4 feste Layer / 5 programmierbare Layer
- * 24 Ausgänge
- * 27 integrierte BSS Eqs



Soundcraft Vi6 Digitales Mischpult

M-Vi6

- * 96 Mono und 8 Stereo Kanäle
- * 32 Mix Busse
- * 35 XLR Ausgänge
- * Fader Konfigurator 32+12



Yamaha LS9-32

M-LS9-32

- * Digitalmischpult mit 32 Mic/Line Eingängen
- * 6 Mix Busse
- * 16 Omni Ausgänge
- * 8x 31 Band Graphic EQ



Yamaha QL1

M-QL1

- * Mix channels: 32 Mono, 8 Stereo
- * Busses: 16 mix, 8 Matrix
- * Local I/O: 16 in, 8 out
- * Fader: 16+2 Master



Allen & Heath SQ6

M-AH-SQ6

- * Digitaler Mixer für Live und Studio
- * 25 Fader / 6 Layer
- * 12x Stereo Mixe (perfekt für In-Ear-Monitoring Setups) + LR
- * Motor Fader
- * USB Audio Streaming
- * 7" Touchscreen



Soundcraft SI Expression2

M-SiEx2

- * 32 Motorfader
- * 54 Mono und 6 Stereo Kanäle
- * 31 Ausgangsbuse
- * Beleuchtete Fader
- * 32 XLR und 4 6,3 Eingänge

	<p>Soundcraft SI Expression</p> <ul style="list-style-type: none"> * 14 Motorfader * 54 Mono und 6 Stereo Kanäle * 31 Ausgangsbusse * Beleuchtete Fader * 32 XLR und 4 6,3 Eingänge 	<p>M-SiEx1</p>	<table border="1"> <tr><td></td><td></td></tr> <tr><td></td><td></td></tr> <tr><td></td><td></td></tr> <tr><td></td><td></td></tr> <tr><td></td><td></td></tr> <tr><td></td><td></td></tr> <tr><td></td><td></td></tr> <tr><td></td><td></td></tr> </table>																
	<p>YAMAHA EMX 5000</p> <ul style="list-style-type: none"> * Powermischer * Eingänge: 8 Mikro, 2 Stereo * 3 Band EQ; 9 Band Master EQ * 48V Phantom * 500W; 300W; 100W 	<p>M-EMX5000</p>	<table border="1"> <tr><td></td><td></td></tr> <tr><td></td><td></td></tr> <tr><td></td><td></td></tr> <tr><td></td><td></td></tr> <tr><td></td><td></td></tr> <tr><td></td><td></td></tr> <tr><td></td><td></td></tr> <tr><td></td><td></td></tr> </table>																
	<p>Yamaha MG 124</p> <ul style="list-style-type: none"> * Kleinmischer mit 12 Eingängen * 6 Mono Kanäle mit zuschaltbarer Phantomspeisung * Flexible Konfiguration * 3 Band EQ * Interne Kanalzug Kompressoren, Kanäle 1 - 4 	<p>M-MG124</p>	<table border="1"> <tr><td></td><td></td></tr> <tr><td></td><td></td></tr> <tr><td></td><td></td></tr> <tr><td></td><td></td></tr> <tr><td></td><td></td></tr> <tr><td></td><td></td></tr> <tr><td></td><td></td></tr> <tr><td></td><td></td></tr> </table>																
	<p>Yamaha MG82</p> <ul style="list-style-type: none"> * 12 Kanal analog Mischpult * 4 Bus system 	<p>M-MG82</p>	<table border="1"> <tr><td></td><td></td></tr> <tr><td></td><td></td></tr> <tr><td></td><td></td></tr> <tr><td></td><td></td></tr> <tr><td></td><td></td></tr> <tr><td></td><td></td></tr> <tr><td></td><td></td></tr> <tr><td></td><td></td></tr> </table>																
	<p>AM-8 Audio Modul</p> <ul style="list-style-type: none"> * 8 Audio Dateien auf einer SD Karte * direkt abspielbar * Out 3,5mm Stereo 	<p>M-AM-8</p>	<table border="1"> <tr><td></td><td></td></tr> <tr><td></td><td></td></tr> <tr><td></td><td></td></tr> <tr><td></td><td></td></tr> <tr><td></td><td></td></tr> <tr><td></td><td></td></tr> <tr><td></td><td></td></tr> <tr><td></td><td></td></tr> </table>																
	<p>BSS FCS 966 OPAL Equalizer</p> <ul style="list-style-type: none"> * Durchstimmbarer Hochpassfilter pro Kanal * Hi / Lo Contour Regler pro Kanal * 15 db Regelbereich * Aussteuerungsanzeige 	<p>M-BSSEQ30</p>	<table border="1"> <tr><td></td><td></td></tr> <tr><td></td><td></td></tr> <tr><td></td><td></td></tr> <tr><td></td><td></td></tr> <tr><td></td><td></td></tr> <tr><td></td><td></td></tr> <tr><td></td><td></td></tr> <tr><td></td><td></td></tr> </table>																



Behringer MX882 Mixer / Splitter

M-MX882

- * 8 In/2 Out Line-Mischer bzw. 2 In/8 Out Line Splitter
- * 8 In/2 Out Line-Mischer bzw. 2 In/8 Out Line Splitter
- * Nutzung als 6 In/6 Out-Aufholverstärker oder DI-Box
- * Präzise Input-/Output-Pegelanzeigen für alle Kanäle



Behringer ADA8000

M-ADA8000

- * 8 Kanal AD / DA Wandler
- * 24Bit bei 44,1/48 kHz
- * 8 integrierte Mikrofon-Verstärker
- * 48V Phantom an jedem Eingang



Tascam LM-8ST

M-LM-8ST

- * Line Mixer
- * 8 Stereo Eingänge
- * Mikrofon Eingang
- * LED Pegel Anzeige
- * Kopfhörer Ausgang



Kompakter 4 Kanal Kopfhörer Verstärker

M-AMP800

- * 4 unabhängige Stereo Verstärker
- * Live und Studio Einsatz
- * Lautstärkereglern mit LED Pegelanzeige
- * 2 Symmetrische Stereo Eingänge



Sennheiser InEar Monitoring

M-SIEM

- * Sender e Band
- * Taschenempfänger
- * Kopfhörer



IMG Stage Line LTR-102

M-LTR-102

- * Line Transformator
- * reduziert Signalstörungen und Brummschleifen
- * 2 Eingänge
- * 2 galvanisch getrennte XLR Ausgänge



IMG Stage Line FGA-202

M-FGA-202

- * Professioneller 2-Kanal-Line-Übertrager
- * reduziert Signalstörungen und Brummschleifen
- * 2 Eingänge
- * 2 galvanisch getrennte XLR Ausgänge



IMG Stageline LSP-102

M-LSP102

- * 2 Kanal 3-fach Splitter
- * 2 Eingänge / 6 Ausgänge
- * 1 symmetrischer XLR-Eingang (600 Ω) pro Kanal
- * 2 galvanisch getrennte, symmetrische XLR-Ausgänge (600 Ω)
- * mit Groundlift-Schalter pro Kanal
- * 1 symetrischer XLR-Direktausgang pro Kanal



BSS AR 133 Aktive DI-Box

M-BSS-GL

- * XLR und Klinkeneingang
- * Ground Lift
- * Spannungsversorgung über 9V oder Phantom 48V
- * Extrem hochohmiger Eingang, z. B. für Tonabnehmersignale



Palmer Pressesplitter 10fach

M-PB10

- * Alle Ein- und Ausgänge symetrisch und trafogetrennt
- * Individuelle Ground Lift Schalter am Eingang
- * Kopfhöreranschluss
- * Einganspegel regelbar
- * GND-Lift Schalter pro Ein- und Ausgang





Fostex MR HD

M-MR8HD

- * 8 Spur Multitrack Recorder
- * 15 Stunden Record
- * 40GB Festplatte
- * USB Schnittstelle
- * CD / DVD Brenner



Zoom H4 - MP3 Recorder



M-ZoomH4



- * Mobiler Audio Recorder
- * Integrierte X/Y Mikrofone
- * 2 XLR Eingänge
- * 2 Kanal USB Audiointerface
- *



	<p>Dolmetscher Kabinen</p> <ul style="list-style-type: none"> * modular leicht aufzubauen * 2 Sitzplätze * hellgrau * entspricht der ISO Norm 4043/2016 	<p>M-Dol-Kab</p>	<table border="1"> <tr><td></td><td></td></tr> <tr><td></td><td></td></tr> <tr><td></td><td></td></tr> <tr><td></td><td></td></tr> <tr><td></td><td></td></tr> <tr><td></td><td></td></tr> <tr><td></td><td></td></tr> <tr><td></td><td></td></tr> </table>																	
	<p>Dolmetscher Tech Set</p> <ul style="list-style-type: none"> * 2 Dolmetscher Pult * 8 Kanal IR Sender * Tech Unit 	<p>M-DolTech-Set</p>	<table border="1"> <tr><td></td><td></td></tr> <tr><td></td><td></td></tr> <tr><td></td><td></td></tr> <tr><td></td><td></td></tr> <tr><td></td><td></td></tr> <tr><td></td><td></td></tr> <tr><td></td><td></td></tr> <tr><td></td><td></td></tr> </table>																	
	<p>Infrarot Taschen Empfänger mit Kopfhörer</p> <ul style="list-style-type: none"> * bis 32 Kanäle wählbar * hervorragende Audioqualität * Handlich und leicht * Preis pro Set incl. anschließender Reinigung 	<p>M-ITEK</p>	<table border="1"> <tr><td></td><td></td></tr> <tr><td></td><td></td></tr> <tr><td></td><td></td></tr> <tr><td></td><td></td></tr> <tr><td></td><td></td></tr> <tr><td></td><td></td></tr> <tr><td></td><td></td></tr> <tr><td></td><td></td></tr> </table>																	
	<p>Personenführungsanlage</p> <ul style="list-style-type: none"> * drahtlose Personenführungsanlage * Hand Sender 6 Kanäle * im lizenzfreien Frequenzbereich Europa: 863-865 MHz * Kinnbügelhörer bis zu 8 Stunden Betriebsdauer * Automatisches Einschalten beim Aufsetzen 	<p>M-PfA</p>	<table border="1"> <tr><td></td><td></td></tr> <tr><td></td><td></td></tr> <tr><td></td><td></td></tr> <tr><td></td><td></td></tr> <tr><td></td><td></td></tr> <tr><td></td><td></td></tr> <tr><td></td><td></td></tr> <tr><td></td><td></td></tr> </table>																	
	<p>Confidea Multi Wireles Conferece System</p> <ul style="list-style-type: none"> * 12 Units * Akku 12 Stunden * Web Control 	<p>M-DiskusFunk</p>	 	<table border="1"> <tr><td></td><td></td></tr> <tr><td></td><td></td></tr> <tr><td></td><td></td></tr> <tr><td></td><td></td></tr> <tr><td></td><td></td></tr> <tr><td></td><td></td></tr> <tr><td></td><td></td></tr> <tr><td></td><td></td></tr> </table>																
	<p>Pioneer XDJ-700</p> <ul style="list-style-type: none"> * großer Touch Screen und Quer-Tastatur * Pro DJ Link * Slip Mode * Beat Synch * Midi zuweisbar 	<p>M-P-XDJ700</p>		<table border="1"> <tr><td></td><td></td></tr> <tr><td></td><td></td></tr> <tr><td></td><td></td></tr> <tr><td></td><td></td></tr> <tr><td></td><td></td></tr> <tr><td></td><td></td></tr> <tr><td></td><td></td></tr> <tr><td></td><td></td></tr> </table>																



Enstufen				
	<p>Fohhn Endstufe</p> <ul style="list-style-type: none"> * 2x 2000W * Modernste CLASS D Technik * Parametric EQ integriert * Integrierte Lausprecher Datenbank 	M-		
	<p>Fohhn System Endstufe</p> <ul style="list-style-type: none"> * 2x 4.600W * Modernste CLASS D Technik * Parametric EQ integriert * Integrierte Lausprecher Datenbank 	M-		
	<p>QSC Endstufe</p> <ul style="list-style-type: none"> * 2x 1200W * Eingänge: XLR * Ausgänge: Speacon 	M-		
	<p>QSC Endstufe</p> <ul style="list-style-type: none"> * 2x 800W * Eingänge: XLR * Ausgänge: Speacon 	M-		
	<p>QSC Endstufe</p> <ul style="list-style-type: none"> * 2x 425W * Eingänge: XLR * Ausgänge: Speacon * Gewicht 11,5 kg 	M-		
	<p>Aktiver Monitor/Fullrangelausprecher</p> <ul style="list-style-type: none"> * integrierte 150 W Class D Endstufe * 3-Kanal Mixer mit 3-Band EQ * 1 Mikrofon/Line/ Instrumenten-Eingang * 1 Mikrofon/Line Eingang und 1 Stereo Cinch CD Input 	M-Aktiv-FR		
	<p>Fostex</p> <ul style="list-style-type: none"> * Aktiv Full Range * Leistung: 20 W * magnetisch geschirmtes Gehäuse 	M-Fostex		



Lausprecher Kling & Freitag

	Kling & Freitag CA106	M-CA106		
	<ul style="list-style-type: none"> * Pasives 2 Wege Bassreflexsystem * Abstrahlwinkel 85°H x 55°V * Nennbelastbarkeit: 240 /480W * 16 Ohm 			

	Kling & Freitag CA1001	M-CA1001		
	<ul style="list-style-type: none"> * 2-Wege Fullrange System mit 10" Tieftöner / 1" Hochtöner * Abstrahlwinkel 90°H x 60°V * Nennbelastbarkeit: 500 /1000W * 6 Ohm 			

	Kling & Freitag CA1201	M-CA1201		
	<ul style="list-style-type: none"> * 2-Wege Fullrange System mit 12" Tieftöner / 1" Hochtöner * Abstrahlwinkel 90°H x 60°V * Nennbelastbarkeit: 500 /1000W * 4 Ohm 			

	Kling & Freitag Line 212 Aktiv	M-L212		
	<ul style="list-style-type: none"> * 2-Wege Aktiv System mit 2x12" Tieftöner / 1,5" Hochtöner * Abstrahlwinkel 90°H x 60°V * Nennbelastbarkeit: 500 /1000W * 4 Ohm 			

	Kling & Freitag SW115 Aktiv	M-SW115		
	<ul style="list-style-type: none"> * Übertragungsbereich ab 33Hz * Maximaler Schalldruck 132,5dB * Nennbelastbarkeit: 1600W * 8 Ohm 			

King und Freitag PIA Serie



Kling & Freitag PIA M

M-KF-PIAM

- * Säulenlautsprecher 2.0
- * bahnbrechende PIA M Lausprecher
- * in akustisch anspruchsvollen Umgebungen
- * umschaltbar zwischen „Bassreflex-Modus“ und „Cardioid-Modus“
- * gleichmäßige Pegelverteilung im gesamten Publikum



Kling & Freitag System Amps

M-KF-

- * Endverstärkerserien sind mit 2x 4600W
- * speziellen Kling & Freitag-Modul-Presets exklusiv für K&F
- * integrierte Lake® Prozessor ist der Standard im Systemprozessing



Kling & Freitag IPX Amp

M-KF-

- * Bis zu 2 x 1200 Watt/4 Ω in 1HE Rack-Gehäus
- * Intelligente DSP-Architektur
- * 40 Multi-Slope-Equalizer
- * Einstellbare Hoch- und Tiefpassfilter
- * Eingangs- und Ausgangs-Delay (jeweils bis zu 2 Sekunden)

Fohhn EasyPort Serie



Fohhn FP-11 Modular weiß

M-FP11

- * Aktivbox, prozessorgesteuert 40W
- * 3 Kanal Mischpult
- * Akku und Netzbetrieb



















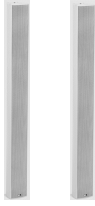



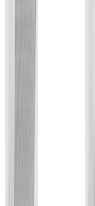

Fohhn FP-22 Modular weiß

M-FP22





- * Aktivbox, prozessorgesteuert 60W
- * 3 Kanal Mischpult, CD Player integriert
- * Akku und Netzbetrieb
- * 2 Empfänger eingebaut



Lausprecher fohhn											
	<p>RC-FP-2 Fohhn Regenschutz-Haube M-FFP22-regen</p> <ul style="list-style-type: none"> * Regenschutz-Haube für FP22 <div style="text-align: right;">  </div> <table border="1" style="width: 100%; border-collapse: collapse;"> <tr><td style="width: 20px; height: 20px;"></td><td style="width: 20px; height: 20px;"></td></tr> <tr><td style="width: 20px; height: 20px;"></td><td style="width: 20px; height: 20px;"></td></tr> <tr><td style="width: 20px; height: 20px;"></td><td style="width: 20px; height: 20px;"></td></tr> <tr><td style="width: 20px; height: 20px;"></td><td style="width: 20px; height: 20px;"></td></tr> <tr><td style="width: 20px; height: 20px;"></td><td style="width: 20px; height: 20px;"></td></tr> </table>										
	<p>Fohhn LX-11 weiß M-LX11</p> <ul style="list-style-type: none"> * Ultrakompakter Lautsprecher für mobile Anwendungen * Ideal für anspruchsvolle Nahfeldanwendungen * Wetterfestes Alu-Gehäuse * Anschlüsse 2x Neutrik NL4 <div style="text-align: right;">  </div> <table border="1" style="width: 100%; border-collapse: collapse;"> <tr><td style="width: 20px; height: 20px;"></td><td style="width: 20px; height: 20px;"></td></tr> <tr><td style="width: 20px; height: 20px;"></td><td style="width: 20px; height: 20px;"></td></tr> <tr><td style="width: 20px; height: 20px;"></td><td style="width: 20px; height: 20px;"></td></tr> <tr><td style="width: 20px; height: 20px;"></td><td style="width: 20px; height: 20px;"></td></tr> <tr><td style="width: 20px; height: 20px;"></td><td style="width: 20px; height: 20px;"></td></tr> </table>										
	<p>Fohhn-NET NA-11 M-NA-11</p> <ul style="list-style-type: none"> * Net USB Adapter * für die Konfiguration aller Fohhn-Net Geräten * * * <div style="text-align: right;">  </div> <table border="1" style="width: 100%; border-collapse: collapse;"> <tr><td style="width: 20px; height: 20px;"></td><td style="width: 20px; height: 20px;"></td></tr> <tr><td style="width: 20px; height: 20px;"></td><td style="width: 20px; height: 20px;"></td></tr> <tr><td style="width: 20px; height: 20px;"></td><td style="width: 20px; height: 20px;"></td></tr> <tr><td style="width: 20px; height: 20px;"></td><td style="width: 20px; height: 20px;"></td></tr> <tr><td style="width: 20px; height: 20px;"></td><td style="width: 20px; height: 20px;"></td></tr> </table>										
	<p>Fohhn LX-150 weiß M-LX150</p> <ul style="list-style-type: none"> * Excelente Sprachverständlichkeit * Hochwertiges Mini-Line-Array * Anschlüsse 2x Neutrik NL4 * incl. Set für Stativ -Montage <div style="text-align: right;">  </div> <table border="1" style="width: 100%; border-collapse: collapse;"> <tr><td style="width: 20px; height: 20px;"></td><td style="width: 20px; height: 20px;"></td></tr> <tr><td style="width: 20px; height: 20px;"></td><td style="width: 20px; height: 20px;"></td></tr> <tr><td style="width: 20px; height: 20px;"></td><td style="width: 20px; height: 20px;"></td></tr> <tr><td style="width: 20px; height: 20px;"></td><td style="width: 20px; height: 20px;"></td></tr> <tr><td style="width: 20px; height: 20px;"></td><td style="width: 20px; height: 20px;"></td></tr> </table>										
	<p>Fohhn LX-601 weiß M-LX150</p> <ul style="list-style-type: none"> * Excelente Sprachverständlichkeit * Hochwertiges Mini-Line-Array * Anschlüsse 2x Neutrik NL4 * incl. Set für Stativ-Montage <div style="text-align: right;">  </div> <table border="1" style="width: 100%; border-collapse: collapse;"> <tr><td style="width: 20px; height: 20px;"></td><td style="width: 20px; height: 20px;"></td></tr> <tr><td style="width: 20px; height: 20px;"></td><td style="width: 20px; height: 20px;"></td></tr> <tr><td style="width: 20px; height: 20px;"></td><td style="width: 20px; height: 20px;"></td></tr> <tr><td style="width: 20px; height: 20px;"></td><td style="width: 20px; height: 20px;"></td></tr> <tr><td style="width: 20px; height: 20px;"></td><td style="width: 20px; height: 20px;"></td></tr> </table>										
	<p>Fohhn LX-220 weiß M-LX220</p> <ul style="list-style-type: none"> * Excelente Sprachverständlichkeit für hohe Reichweiten * Hochwertiges 4 wege Hybrid Mini-Line-Array * Anschlüsse 2x Neutrik NL4 * incl. Set für Stativ-Montage <div style="text-align: right;">  </div> <table border="1" style="width: 100%; border-collapse: collapse;"> <tr><td style="width: 20px; height: 20px;"></td><td style="width: 20px; height: 20px;"></td></tr> <tr><td style="width: 20px; height: 20px;"></td><td style="width: 20px; height: 20px;"></td></tr> <tr><td style="width: 20px; height: 20px;"></td><td style="width: 20px; height: 20px;"></td></tr> <tr><td style="width: 20px; height: 20px;"></td><td style="width: 20px; height: 20px;"></td></tr> <tr><td style="width: 20px; height: 20px;"></td><td style="width: 20px; height: 20px;"></td></tr> </table>										
	<p>Fohhn XS 30 Aktiv Subwoofer weiß M-XS30</p> <ul style="list-style-type: none"> * 1500W Clas D Verstärker * 15" Langhub * DSP eingebaut <div style="text-align: right;">  </div> <table border="1" style="width: 100%; border-collapse: collapse;"> <tr><td style="width: 20px; height: 20px;"></td><td style="width: 20px; height: 20px;"></td></tr> <tr><td style="width: 20px; height: 20px;"></td><td style="width: 20px; height: 20px;"></td></tr> <tr><td style="width: 20px; height: 20px;"></td><td style="width: 20px; height: 20px;"></td></tr> <tr><td style="width: 20px; height: 20px;"></td><td style="width: 20px; height: 20px;"></td></tr> <tr><td style="width: 20px; height: 20px;"></td><td style="width: 20px; height: 20px;"></td></tr> </table>										

	<p>Flüsterkoffer / Tourguide</p> <ul style="list-style-type: none"> * Tourguide / digital inkl. Headsetsender * Sennheiser SK2020-D / HDE2020-D-II * Handsender Headsetsender, 20 Empfänger 	<p>M-Tourguide</p>	<table border="1"> <tr><td></td><td></td></tr> <tr><td></td><td></td></tr> <tr><td></td><td></td></tr> <tr><td></td><td></td></tr> <tr><td></td><td></td></tr> </table>										
	<p>Wireles 4G, 5G LTE Router</p> <ul style="list-style-type: none"> * schnelles Internet LTE-Verbindung * Internet kommt via Funk über die SIM-Karte. * Internet Flat 	<p>M-5G-Router</p>	<table border="1"> <tr><td></td><td></td></tr> <tr><td></td><td></td></tr> <tr><td></td><td></td></tr> <tr><td></td><td></td></tr> <tr><td></td><td></td></tr> </table>										
	<p>Wireles 4G, 5G LTE Router DUAL SIM LTE</p> <ul style="list-style-type: none"> * schnelles Internet LTE-Verbindung * Internet kommt via Funk über 2 SIM-Karten. * Internet-Flat * Mini Mac 	<p>M-5G-DS-Router</p>	<table border="1"> <tr><td></td><td></td></tr> <tr><td></td><td></td></tr> <tr><td></td><td></td></tr> <tr><td></td><td></td></tr> <tr><td></td><td></td></tr> </table>										
	<p>Wireles 4G, 5G LTE Router</p> <ul style="list-style-type: none"> * schnelles Internet LTE-Verbindung * Internet kommt via Funk über die SIM-Karte. * Internet 20G 	<p>M-4G-Router</p>	<table border="1"> <tr><td></td><td></td></tr> <tr><td></td><td></td></tr> <tr><td></td><td></td></tr> <tr><td></td><td></td></tr> <tr><td></td><td></td></tr> </table>										
	<p>K&M Lautsprecher Stativ</p> <ul style="list-style-type: none"> * 2x Boxenstative * 1x Boxenstativ-Tasche * Material Alu 	<p>M-LSSTs</p>	<table border="1"> <tr><td></td><td></td></tr> <tr><td></td><td></td></tr> <tr><td></td><td></td></tr> <tr><td></td><td></td></tr> <tr><td></td><td></td></tr> </table>										
	<p>K&M Lautsprecher Stativ weiß</p> <ul style="list-style-type: none"> * 2x Boxenstative * 1x Boxenstativ-Tasche * Material Alu 	<p>M-LSSTw</p>	<table border="1"> <tr><td></td><td></td></tr> <tr><td></td><td></td></tr> <tr><td></td><td></td></tr> <tr><td></td><td></td></tr> <tr><td></td><td></td></tr> </table>										
	<p>K&M Lautsprecher Kurbel Stativ</p> <ul style="list-style-type: none"> * variable Höheneinstellung mittels Handkurbel * Mechanik aus gehärtetem Stahl * von 1,24 m bis 2,15 m ausfahrbar * max. bis 50 kg belastbar 	<p>M-LSSTK</p>	<table border="1"> <tr><td></td><td></td></tr> <tr><td></td><td></td></tr> <tr><td></td><td></td></tr> <tr><td></td><td></td></tr> <tr><td></td><td></td></tr> </table>										

Kabel	
	<p>XLR Kabel M-XLR03</p> <ul style="list-style-type: none"> * XLR Kabel 0,5m * XLR Kabel 1,0m * XLR Kabel 3,0m
	<p>XLR Kabel M-XLR10</p> <ul style="list-style-type: none"> * XLR Kabel 6m * XLR Kabel 10m
	<p>XLR Kabel M-XLR20</p> <ul style="list-style-type: none"> * XLR Kabel 15m * XLR Kabel 20m
	<p>XLR Kabel M-XLR50</p> <ul style="list-style-type: none"> * XLR Kabel 50m * Kabeltrommel
	<p>XLR Kabel M-XLR100</p> <ul style="list-style-type: none"> * XLR Kabel 100m * Kabeltrommel
	<p>XLR Kabel Multicore M-XLPMC03</p> <ul style="list-style-type: none"> * XLR Kabel Multicore 3m
	<p>XLR Kabel Multicore M-XLRMC35</p> <ul style="list-style-type: none"> * XLR Kabel Multicore 25m * * * *

Speakon Kabel					
	<p>Speakon Kabel Neutrik</p> <ul style="list-style-type: none"> * 3m * Lautsprecher Kabel * 2x 2,5mm² 	M-SPK03			
	<p>Speakon Kabel Neutrik</p> <ul style="list-style-type: none"> * 6m * Lautsprecher Kabel * 2x 2,5mm² 	M-SPK06			
	<p>Speakon Kabel Neutrik</p> <ul style="list-style-type: none"> * 10m * Lautsprecher Kabel * 2x 2,5mm² 	M-SPK10			
	<p>Speakon Kabel Neutrik</p> <ul style="list-style-type: none"> * 15m * Lautsprecher Kabel * 2x 2,5mm² 	M-SPK15			
	<p>Speakon Kabel Neutrik</p> <ul style="list-style-type: none"> * 25m * Lautsprecher Kabel * 2x 2,5mm² 	M-SPK25			
	<p>Speakon Kabel Neutrik</p> <ul style="list-style-type: none"> * 50m * Lautsprecher Kabel * 2x 2,5mm² 	M-SPK50			
	<p>Speakon Verbinder Neutrik</p> <ul style="list-style-type: none"> * NL4MMX * Adapter zur Verlängerung von Speakon Kabel * * * 	M-SPV			

IT Technik

	<p>Apple MacBook Pro</p> <ul style="list-style-type: none"> * 15" * i7 * * 	<p>M-AMB-Pro</p>	<table border="1"> <tr><td></td><td></td></tr> <tr><td></td><td></td></tr> <tr><td></td><td></td></tr> <tr><td></td><td></td></tr> <tr><td></td><td></td></tr> </table>										
	<p>Apple Mac Mini</p> <ul style="list-style-type: none"> * i5 * * 	<p>M-AM-MM</p>	<table border="1"> <tr><td></td><td></td></tr> <tr><td></td><td></td></tr> <tr><td></td><td></td></tr> <tr><td></td><td></td></tr> <tr><td></td><td></td></tr> </table>										
	<p>Apple iPad 10,5</p>	<p>M-AiP10</p>	<table border="1"> <tr><td></td><td></td></tr> <tr><td></td><td></td></tr> <tr><td></td><td></td></tr> <tr><td></td><td></td></tr> <tr><td></td><td></td></tr> </table>										
	<p>Lenovo Notebook</p> <ul style="list-style-type: none"> * bis 1080p/60 * L450 / L480 	<p>M-LNB1080</p>	<table border="1"> <tr><td></td><td></td></tr> <tr><td></td><td></td></tr> <tr><td></td><td></td></tr> <tr><td></td><td></td></tr> <tr><td></td><td></td></tr> </table>										
	<p>Lenovo Notebook</p> <ul style="list-style-type: none"> * 4K * P51s * * * 	<p>M-LNB4k</p>	<table border="1"> <tr><td></td><td></td></tr> <tr><td></td><td></td></tr> <tr><td></td><td></td></tr> <tr><td></td><td></td></tr> <tr><td></td><td></td></tr> </table>										
	<p>iMac</p> <ul style="list-style-type: none"> * Intel Core i5 * 	<p>M-AiM15</p>	<table border="1"> <tr><td></td><td></td></tr> <tr><td></td><td></td></tr> <tr><td></td><td></td></tr> <tr><td></td><td></td></tr> <tr><td></td><td></td></tr> </table>										
	<p>iMac-FC</p> <ul style="list-style-type: none"> * mit Final Cut * * 	<p>M-AiM-FC</p>	<table border="1"> <tr><td></td><td></td></tr> <tr><td></td><td></td></tr> <tr><td></td><td></td></tr> <tr><td></td><td></td></tr> <tr><td></td><td></td></tr> </table>										

IT Technik													
	<p>Media PC</p> <ul style="list-style-type: none"> * Hochleistungs PC i7 * 1TB SSD * 	<p>M-MPCi7</p>	<table border="1"> <tr><td></td><td></td></tr> <tr><td></td><td></td></tr> <tr><td></td><td></td></tr> <tr><td></td><td></td></tr> <tr><td></td><td></td></tr> </table>										
	<p>Microsoft surface 3 pro</p> <ul style="list-style-type: none"> * ultra leicht * Full HD * SSD 128Gb * Akku Laufzeit 10 Stunden 	<p>M-MS3Pro</p>	<table border="1"> <tr><td></td><td></td></tr> <tr><td></td><td></td></tr> <tr><td></td><td></td></tr> <tr><td></td><td></td></tr> <tr><td></td><td></td></tr> </table>										
	<p>Android Tablet</p> <ul style="list-style-type: none"> * Full HD * Android 6 	<p>M-TBA</p>	<table border="1"> <tr><td></td><td></td></tr> <tr><td></td><td></td></tr> <tr><td></td><td></td></tr> <tr><td></td><td></td></tr> <tr><td></td><td></td></tr> </table>										
	<p>Intel NUC mini PC i7</p> <ul style="list-style-type: none"> * Mini PC mit Windows 10 * von Intel konfiguriert * auf optimale Leistung abgestimmt * HDMI und MDP Ausgang 	<p>M-NUCi7</p>	<table border="1"> <tr><td></td><td></td></tr> <tr><td></td><td></td></tr> <tr><td></td><td></td></tr> <tr><td></td><td></td></tr> <tr><td></td><td></td></tr> </table>										
	<p>Intel NUC mini PC i5</p> <ul style="list-style-type: none"> * Mini PC mit Windows 10 * von Intel konfiguriert * auf optimale Leistung abgestimmt * HDMI und MDP Ausgang 	<p>M-NUCi5</p>	<table border="1"> <tr><td></td><td></td></tr> <tr><td></td><td></td></tr> <tr><td></td><td></td></tr> <tr><td></td><td></td></tr> <tr><td></td><td></td></tr> </table>										
	<p>Raspberry pi 3B+</p> <ul style="list-style-type: none"> * 4 USB * 1080P/60 * * 	<p>M-Pi3</p>	<table border="1"> <tr><td></td><td></td></tr> <tr><td></td><td></td></tr> <tr><td></td><td></td></tr> <tr><td></td><td></td></tr> <tr><td></td><td></td></tr> </table>										
	<p>Raspberry 4</p> <ul style="list-style-type: none"> * 2 HDMI * 4K * 	<p>M-Pi44K</p>	<table border="1"> <tr><td></td><td></td></tr> <tr><td></td><td></td></tr> <tr><td></td><td></td></tr> <tr><td></td><td></td></tr> <tr><td></td><td></td></tr> </table>										

IT Technik

	Rasberry 3B+ Media Player * 1080p/60 * Video von USB automatisch abspielen * HDMI Kabel *	M-Pi3-USBVP		
---	--	-------------	--	--

	Apple TV * 1080p/60 * Fotos und Videos vom iPad oder iPhone * 802.11 ac Wi-Fi	M-ATV		
---	---	-------	--	--

	iPad Bodenständer * mit Diebstahlsicherung *	M-iPad-Stand		
---	---	--------------	--	--

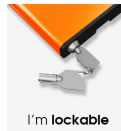

	Logitech Funk Tastatur * Funk Tastatur * Maus Set * Deutsch QWERTZ	M-LoFTM		
--	--	---------	--	--

	Tintendrucker Farbe HP / Canon A4	M-TDA4		
	Tintendrucker Farbe HP / Canon A3	M-TDA3		
	Tintendrucker / Scanner Farbe HP / Canon A3	M-TDSA3		

Laserdrucker Farbe HP / Canon A4	M-LDF-A4		
---	----------	--	--

	Laserdrucker SW A4 * Bis zu 2.400 x 600 dpi Auflösung * USB 2.0 Full-Speed Schnittstelle	M-LDSW-A4		
---	---	-----------	--	--

IT Technik



Ducker Papier	A4 80g	250 Blatt	DPA480		
Ducker Papier	A4 90g	250 Blatt	DPA490		
Ducker Papier	A3 80g	250 Blatt	DPA380		



Crane			M-Crane		
* Notebook Ständer					



LTE WLAN Router			M-LTE-WRT		
* Router incl. Telekom LTE Tages-Flat					



LAN Splitter		Mietpreis / Veranstaltung	M-LAN-SW8		
* 5 fach					



LAN Splitter	PoE	Mietpreis / Veranstaltung	M-LAN-SW8		
* 8 fach					













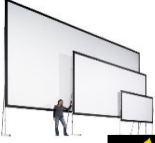

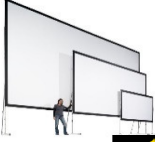

LAN Splitter	PoE+	Mietpreis / Veranstaltung	M-LAN-SW16		
* 16 fach					

























LAN Kabel	1 - 5m	Mietpreis / Veranstaltung	M-LK5		
LAN Kabel	5 - 10m		M-LK10		
LAN Kabel	10 - 20m		M-LK20		
LAN Kabel	20 - 50m		M-LK50		
LAN Kabel	50 - 75m		M-LK75		
LAN Kabel	100m auf Kabeltrommel		M-LK100		

Leinwände 4:3

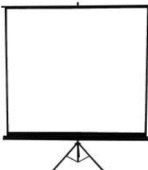
 	<p>Leinwand AV Stumpfl</p> <ul style="list-style-type: none"> * Vario 32 Standardgröße 4:3 * Außenmaß: 210 x 160 * Bildmaß: 200 x 150 	<p>M-L210</p>	
 	<p>Leinwand AV Stumpfl</p> <ul style="list-style-type: none"> * Vario 32 Standardgröße 4:3 * Außenmaß: 240 x 180 * Bildmaß: 230 x 170 	<p>M-L240 M-L240R</p>	
 	<p>Leinwand AV Stumpfl</p> <ul style="list-style-type: none"> * Vario 32 Standardgröße 4:3 * Außenmaß: 280 x 210 * Bildmaß: 270 x 200 	<p>M-L280 M-L280R</p>	
 	<p>Leinwand AV Stumpfl</p> <ul style="list-style-type: none"> * Vario 32 Standardgröße 4:3 * Außenmaß: 320 x 245 * Bildmaß: 310 x 235 	<p>M-L320 M-L320R</p>	
 	<p>Leinwand AV Stumpfl</p> <ul style="list-style-type: none"> * Vario 32 Standardgröße 4:3 * Außenmaß: 360 x 270 * Bildmaß: 350 x 260 	<p>M-L380 M-L380R</p>	
 	<p>Leinwand AV Stumpfl</p> <ul style="list-style-type: none"> * Vario 32 Standardgröße 4:3 * Außenmaß: 400 x 300 * Bildmaß: 390 x 290 	<p>M-L400 M-L400RR</p>	
 	<p>Leinwand AV Stumpfl</p> <ul style="list-style-type: none"> * Vario 32 Standardgröße 4:3 * Außenmaß: 500 x 380 * Bildmaß: 490 x 370 	<p>M-L500 M-L500R</p>	

Leinwände 16:9

 	Leinwand AV Stumpfl * Vario 32 Standardgröße 16:9 * Außenmaß: 312 x 180 * Bildmaß: 300 x 160	M-L312 M-L312wei		
 	Leinwand AV Stumpfl * Vario 32 Standardgröße 16:9 * Außenmaß: 365 x 210 * Bildmaß: 355 x 200	M-L365		
 	Leinwand AV Stumpfl * Vario 32 Standardgröße 16:9 * Außenmaß: 428 x 245 * Bildmaß: 410 x 235	M-L428		
 	Leinwand AV Stumpfl * Vario 32 Standardgröße 16:9 * Außenmaß: 472x 270 * Bildmaß: 450 x 260	M-L472wei		
 	Leinwand AV Stumpfl invisnap * Vario 64 Standardgröße 16:9 * Außenmaß: 650 x 370 Aufpro * Bildmaß: 640 x 360 weißer Rand * innovatives, hochwertiges, flexibles Leinwandssystem	M-L650wei		
 	Leinwand AV Stumpfl invisnap * Vario 64 Standardgröße 16:9 * Außenmaß: 980 x 430 Aufpro * Bildmaß: 970 x 420 weißer Rand * innovatives, hochwertiges, flexibles Leinwandssystem	M-L980		
 	Leinwand AV Stumpfl invisnap * Vario 64 * Außenmaß: 810 x 265 Aufpro * Bildmaß: 805 x 260 weißer Rand * innovatives, hochwertiges, flexibles Leinwandssystem	M-L810		

 	<p>Leinwand AV Stumpfl invisnap</p> <ul style="list-style-type: none"> * Vario 64 * Außenmaß: 1145 x 485 Aufpro * Bildmaß: 1135 x 475 weißer Rand * innovatives, hochwertiges, flexibles Leinwandssystem 	<p>M-L1145</p>	<table border="1"> <tr><td></td><td></td></tr> <tr><td></td><td></td></tr> <tr><td></td><td></td></tr> <tr><td></td><td></td></tr> <tr><td></td><td></td></tr> </table>										
Stativ Leinwände													
	<p>Stativ Leinwand 175 x 175</p> <p>Stativ Leinwand 180 x 180</p>	<p>M-L175</p> <p>M-L180</p>	<table border="1"> <tr><td></td><td></td></tr> <tr><td></td><td></td></tr> <tr><td></td><td></td></tr> <tr><td></td><td></td></tr> <tr><td></td><td></td></tr> </table>										
	<p>Stativ Leinwand 200 x 200</p> <p>Stativ Leinwand 200 x 150 mobil</p>	<p>M-L200</p> <p>M-L200CM</p>	<table border="1"> <tr><td></td><td></td></tr> <tr><td></td><td></td></tr> <tr><td></td><td></td></tr> <tr><td></td><td></td></tr> <tr><td></td><td></td></tr> </table>										
	<p>Stativ Leinwand 180 x 135 Design</p>	<p>M-L180D</p>	<table border="1"> <tr><td></td><td></td></tr> <tr><td></td><td></td></tr> <tr><td></td><td></td></tr> <tr><td></td><td></td></tr> <tr><td></td><td></td></tr> </table>										
	<p>Stativ Leinwand 240 x 240</p>	<p>M-L240</p>	<table border="1"> <tr><td></td><td></td></tr> <tr><td></td><td></td></tr> <tr><td></td><td></td></tr> <tr><td></td><td></td></tr> <tr><td></td><td></td></tr> </table>										
	<p>Stativ Leinwand 200 x 200 Design</p>	<p>M-L200</p>	<table border="1"> <tr><td></td><td></td></tr> <tr><td></td><td></td></tr> <tr><td></td><td></td></tr> <tr><td></td><td></td></tr> <tr><td></td><td></td></tr> </table>										
	<p>Supernova One</p> <ul style="list-style-type: none"> * 84" 16:9 * super High Gain * Bildmaß 186x105 * Rahmen silber 	<p>M-DNPS84</p>	<table border="1"> <tr><td></td><td></td></tr> <tr><td></td><td></td></tr> <tr><td></td><td></td></tr> <tr><td></td><td></td></tr> <tr><td></td><td></td></tr> </table>										

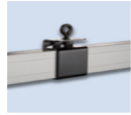

Ankerpunkte für Stumpfl Leinwände

* geeignet für Monoblock 32

M-AVST-AP32





Videofunk

* 3G HD-SDI und HDMI Videofunk 5 GHz Indoor

M-Videofunk

Mehr Erfolg mit Digital Signage DIE MÖGLICHKEITEN SIND GRENZENLOS

	NEC Multisync 984UHD	M-N98	
	* Diagonale 98" / 248cm		
	* Auflösung: 3840 x 2160 4K		
	* Abmessungen: 219 x 125 x 12cm		
	* Gewicht: 90kg Vesa 600x400		
	* Leistungsaufnahme: 350W		

	NEC Multisync 864UHD	M-N86	
	* Diagonale 86" / 217cm 400 cd/m²		
	* Auflösung: 3840 x 2160 4K		
	* Abmessungen: 193 x 110 x 7,4cm		
	* Gewicht: 64kg Vesa 600x400		
	* Leistungsaufnahme: 330W		

	NEC Multisync 751UHD	M-N86	
	* Diagonale 75" / 189cm		
	* Auflösung: 3840 x 2160 4K		
	* Abmessungen: 193 x 110 x 7,4cm		
	* Gewicht: 55kg Vesa 600x400		
	* Leistungsaufnahme: 255W A+		

	NEC Multisync 651UHD	M-N86	
	* Diagonale 65" / 163,9cm		
	* Auflösung: 3840 x 2160 4K		
	* Abmessungen: 145 x 83 x 6,5cm		
	* Gewicht: 37kg Vesa 600x400		
	* Leistungsaufnahme: 120W A+		

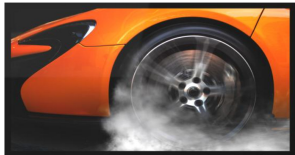
	NEC Multisync 55"	M-N55	
	* 55" / 138		
	* Auflösung: 3840 x 2160 4K		
	* Abmessungen: 124 x 71 x 7cm		
	* Gewicht: 27kg Vesa 600x400		
	* Leistungsaufnahme: 120W A+		

	NEC Multitouch Tisch	M-N55MT	
	* Touch Tisch mit 55" Multitouch Display		
	* Bilddiagonale 55" / 139cm		
	* Höhe: 850mm		
	* Farbe: weiß		





 <p>55" iiyama ProLite LH55B25B-B1 IPS 700 cd/m² 24/7</p>	iiyama High Brightnes		M-55HB		
	* 55" / 139cm				
	* 55" Digital Signage Display mit Full HD Auflösung				
	*				
	*				
	*				

 <p>NEC</p>	NEC Multisync		M-49		
	* 49" / 124cm 3840 x 2160				
	* Abmessungen (B x H x T) [mm]1.103,4 x 636,2 x 61,				
	* IPS mit Edge LED-Hintergrundbeleuchtung				
	* Helligkeit [cd/m²]700				
	* Gewicht: 23kg Vesa 300x300				

 <p>NEC</p>	NEC Multisync		M-43		
	* 43" / 108cm 3840 x 2160				
	* Abmessungen (B x H x T) [mm]968,2 x 561 x 67,1				
	* IPS mit Edge LED-Hintergrundbeleuchtung				
	* Helligkeit [cd/m²]700				
	* Gewicht: 18,5kg Vesa 300x300				

 <p>NEC</p>	NEC Multisync		M-27		
	* 27" / 69cm				
	* Abmessungen (B x H x T) [mm]359,8 x 628,4 - 651,6 x 250				
	* IPS mit Edge LED-Hintergrundbeleuchtung				
	* Helligkeit [cd/m²]700				
	* Gewicht: 9,5kg Vesa 300x300				

 <p>NEC</p>	NEC Multisync		M-24		
	* 24" / 60cm				
	* Abmessungen (B x H x T) [mm]968,2 x 561 x 67,1				
	* IPS mit Edge LED-Hintergrundbeleuchtung				
	* Helligkeit [cd/m²]250				
	* Gewicht: 9,2kg Vesa 300x300				

 <p>NEC</p>	NEC Multisync		M-22		
	* 22" / 55cm				
	* Abmessungen (B x H x T) [mm]968,2 x 561 x 67,1				
	* IPS mit Edge LED-Hintergrundbeleuchtung				
	* Helligkeit [cd/m²]250				
	* Gewicht: 9,2kg Vesa 300x300				



Display -Wal 4N55

M-4N55

- * im Set 2x2
- * NEC 55" Monitore mit Steg
- * Gestell rollbar
- * Bild: 2,44 x 1,40cm
- *



Audipack Screenlifter

M-ASL120

- * bis zu 120 kg
- * Multi -Vesa
- * Max Höhe 1800mm
- * 230V
- * Gewicht: 32kg





Audipack System 900

M-ADS

- * Design Säule ohne Rollen
- * für Displays bis 65"
- * 900 series Floor stands
- * Combine style with strength
- * easy on the eye, yet easy to install





Audipack System 900

M-ADSR

- * Design Säule mit Rollen
- * für Displays bis 65"
- * 900 series Floor stands
- * Combine style with strength
- * easy on the eye, yet easy to install





Audipack

M-SDK

- * Design Säule mit Rollen
- * für Displays bis 55"
- * 900 series Floor stands
- * Combine style with strength
- * easy on the eye, yet easy to install



Audipack

- * Notebook Ablage Design Säule Serie 900

Licht



MA Lighting MA on PC

M-GM-PC

- * intuitive Grafikschnittstelle
- * Minimale Set-up Zeiten
- * Steuerung über Touchscreen
- * 3D Visualisierungs Software
- *



1



Command Wing

MComWing

- * Echtheits-Kontrolle 2048 Parameter
- * 20 zusätzliche Fader
- * Anschluss via USB
- *
- * Gewicht: 4kg

1



ETC SmartFade 1248

M-ETC1248

- * 48 Sequenzen mit 24 Schritten
- * Manuelle oder zeitgesteuerte Fades
- * SD Kartenslot
- *

1



Shotech SC-2412

M-LC2412

- * 48 Kanal Lichtsteuerpult
- * Ideal zur Steuerung konventioneller Lichtdimmer
- *

1



Behringer LC2412

M-LC2412

- * professionelles 24 Kanal DMX Lichtsteuerpult
- * bis 120 Bühnenbilder in 10 Bänken
- * Lauflichtsteuerung
- * 2 Spezialkanäle mit Schaltfunktion

1



Connex DS-460 DMX Splitter

M-DS460



- * galvanisch getrennte Ein- und Ausgänge
- * alle Anschlüsse in 3 und 5 Pol
- * ESD geschützt
- * DMX Eingangstester

1

	<p>ARRI 1000W Studio</p> <ul style="list-style-type: none"> * Lampenleistung 1000W 3200°K * Abstrahlwinkel: 9° - 59° * Drehbare Torblende * Farbfilterrahmen * Safety, Rohrhaken 	<p>M-ARRI1000</p>	<table border="1"> <tr><td></td><td></td></tr> <tr><td></td><td></td></tr> <tr><td></td><td></td></tr> <tr><td></td><td></td></tr> <tr><td></td><td></td></tr> <tr><td></td><td></td></tr> <tr><td></td><td></td></tr> <tr><td></td><td></td></tr> <tr><td></td><td></td></tr> <tr><td></td><td></td></tr> </table>																				
	<p>ARRI 650W</p> <ul style="list-style-type: none"> * Lampenleistung 650W 3200°K * Abstrahlwinkel: 12° - 52° * Drehbare Torblende * Farbfilterrahmen * Safety, Rohrhaken 	<p>M-ARRI650</p>	<table border="1"> <tr><td></td><td></td></tr> <tr><td></td><td></td></tr> <tr><td></td><td></td></tr> <tr><td></td><td></td></tr> <tr><td></td><td></td></tr> <tr><td></td><td></td></tr> <tr><td></td><td></td></tr> <tr><td></td><td></td></tr> <tr><td></td><td></td></tr> <tr><td></td><td></td></tr> </table>																				
	<p>ARRI 300W</p> <ul style="list-style-type: none"> * Lampenleistung 300W 3200°K * Abstrahlwinkel: 14° - 53° * Drehbare Torblende * Farbfilterrahmen * Safety, Rohrhaken 	<p>M-ARRI300</p>	<table border="1"> <tr><td></td><td></td></tr> <tr><td></td><td></td></tr> <tr><td></td><td></td></tr> <tr><td></td><td></td></tr> <tr><td></td><td></td></tr> <tr><td></td><td></td></tr> <tr><td></td><td></td></tr> <tr><td></td><td></td></tr> <tr><td></td><td></td></tr> <tr><td></td><td></td></tr> </table>																				
	<p>ARRI 2000W</p> <ul style="list-style-type: none"> * Lampenleistung 2000W 3200°K * Abstrahlwinkel: 12° - 57° * Drehbare Torblende * Farbfilterrahmen * Safety, Rohrhaken 	<p>M-ARR2000</p>	<table border="1"> <tr><td></td><td></td></tr> <tr><td></td><td></td></tr> <tr><td></td><td></td></tr> <tr><td></td><td></td></tr> <tr><td></td><td></td></tr> <tr><td></td><td></td></tr> <tr><td></td><td></td></tr> <tr><td></td><td></td></tr> <tr><td></td><td></td></tr> <tr><td></td><td></td></tr> </table>																				
	<p>GLP X4S weiß</p> <ul style="list-style-type: none"> * 7 x 15W Multicolor RGBW * Abstrahlwinkel 7° - 50° * Zoom * Gewicht: 5,8kg * https://www.youtube.com/watch?v=NnTfdLzA9Zk 	<p>M-GLPX4S</p>	<table border="1"> <tr><td></td><td></td></tr> <tr><td></td><td></td></tr> <tr><td></td><td></td></tr> <tr><td></td><td></td></tr> <tr><td></td><td></td></tr> <tr><td></td><td></td></tr> <tr><td></td><td></td></tr> <tr><td></td><td></td></tr> <tr><td></td><td></td></tr> <tr><td></td><td></td></tr> </table>																				
	<p>ClayPaky A.leda B-eye K10 weiß</p> <ul style="list-style-type: none"> * 19 x 15W LED * Rotierende Frontlinse * Wash und Beam * Gewicht: 15kg * https://www.youtube.com/watch?v=MuvTKMnh9n8 	<p>M-A.leda-BEYE</p>	<table border="1"> <tr><td></td><td></td></tr> <tr><td></td><td></td></tr> <tr><td></td><td></td></tr> <tr><td></td><td></td></tr> <tr><td></td><td></td></tr> <tr><td></td><td></td></tr> <tr><td></td><td></td></tr> <tr><td></td><td></td></tr> <tr><td></td><td></td></tr> <tr><td></td><td></td></tr> </table>																				
	<p>ClayPaky Glow-ups weiß</p> <ul style="list-style-type: none"> * 4x 10W LED 1200lx * Zoom 15° - 30° * Akku Laufzeit bis zu 20 Stunden * Ladezeit 4 Stunden * Gewicht: 15kg 	<p>M-Glow-upsw</p>	<table border="1"> <tr><td></td><td></td></tr> <tr><td></td><td></td></tr> <tr><td></td><td></td></tr> <tr><td></td><td></td></tr> <tr><td></td><td></td></tr> <tr><td></td><td></td></tr> <tr><td></td><td></td></tr> <tr><td></td><td></td></tr> <tr><td></td><td></td></tr> <tr><td></td><td></td></tr> </table>																				



	ClayPaky HPE700 alpha spot weiß	M-HPE700w		
	<ul style="list-style-type: none"> * 700W Entladungslampe * Pan / Tilt: 540 / 250 * 15 Gobos (7 rotierend; 8 Statisch) * Gewicht: 22,9 Kg * https://www.youtube.com/watch?v=KX7X3F3LkEw&frags=pl%2Cwn 			
			2	

	ClayPaky scenios profile	M-HPSP		
	<ul style="list-style-type: none"> * 1400W Entladungslampe * 4 komplett schließene Blendenmischer * IP 20 * Gewicht: 41 Kg * https://www.youtube.com/watch?v=JcsB28V4b_8 			
			2	

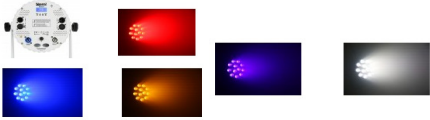
	BAC404W weiß	UV LED	M-BAC404W	
	<ul style="list-style-type: none"> * 4x18W RGBAW-UV * 2680lx * IR Fernbedienung * Gewicht: 1,0kg * https://www.tronios.de/lighting/led-par-cans/bac404w-aluminum-led-spot-4x-18w-6-in-1-leds/ 			
			2	

	BAC506W weiß	UV LED	M-BAC506W	
	<ul style="list-style-type: none"> * 12x18W RGBAW-UV * 7060 lx * IR Fernbedienung * Gewicht: 3,3kg * https://www.tronios.de/lighting/led-par-cans/bac506w-aluminum-led-par/ 			
			2	

	Astera AX3	Wireles	Akku	M-LAX3-Set	
	<ul style="list-style-type: none"> * 8x LED Spots 15W RGB * klein und kompakt * Akkulaufzeit bis zu 20 Stunden * Funk Modul Fernbedienung * Laden im Transportkoffer 				
				16	

	Eurolite PMB8			
	<ul style="list-style-type: none"> * 8x 30W RGB LED * Abstrahlwinkel 30° * Gewicht: 7,7kg 			
			8	

	Asterax AX5	Wireless	Akku	M-LAX5-Set		
	<ul style="list-style-type: none"> * 3x 15W LED RGBAW * 4800lx * Akkulaufzeit bis zu 20 Stunden * Funk Modul Fernbedienung * 3,5kg 	IP65			8	

	Futurelight PLS-5R	M-P350konf4				
	<ul style="list-style-type: none"> * Spot Movinghead * 350W Entladungslampe * Strobe-Effekt * 14 statische 8 rotierende Gobos * Gewicht: 16kg 				4	

	Futurelight Eye-15	M-				
	<ul style="list-style-type: none"> * 10x15W RGBW * LED Washer * Bicolor LED kalt- und warmweiß * Gewicht: 11kg 				2	

	BeamZ	M-BeamZP64				
	<ul style="list-style-type: none"> * 18x 6W 4in 1 LED * Leichtes Aluminium-Gehäuse * PAR 64 * mit Doppelhalter * Gewicht: 2,3kg 				20	

	ETC Profiler 15° - 30°	M-				
	<ul style="list-style-type: none"> * Abstrahlwinkel 15 - 30° * Lüfterlos * Lampe 750W 				2	

	ETC Profiler 25° - 50°	M-				
	<ul style="list-style-type: none"> * Abstrahlwinkel 25 - 50° * Lüfterlos * Lampe 750W 				2	

	SGM Q7 LED RGBW	M-		
	* Outdoor Flächenfluter	IP65		
	* 2000x RGB SMD LED			
	* weiß 19.000 Lumen			
	* alle an 2.800 Lumen			
	* 8,1 kg			

	SGM P5 RGBW	Wireles	M-	
	* Outdoor Flächenfluter			
	* IP65			
	* 44x10W LED			
	* Matrixfähig			
	* 8,9kg			

	ETC S4 PAR	M-		
	* für Lampen bis 750W			
	* Brennweite 25° - 45°			
	* Robustes Alu-Gehäuse			

	Robe Pointe	M-		
	* Spot, Beam und Wash			
	* 280 W Entladungslampe			
	* 1 statisches und 1 rotierendes Gobo			
	* 15kg			

	Robe BMFL Spot	M-		
	* Lampe 1700W			
	* 40.000 lm			
	* 35,8kg			
	* https://www.youtube.com/watch?v=bknO8mkrqVM			

	Litecraft AT10	M-		
	* Outdoor Paar IP65			
	* 18x10W RGBA			
	* Erweitertes Farbspektrum durch Amber LED			
	* Abstrahlwinkel 25°			

26

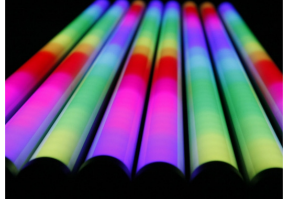
	Asterax AX1 Akku LED TUBE	M-		
	* RGBW LED			
	* Funkmodul			
	* bis zu 20 Stunden Akku Laufzeit			
	https://www.youtube.com/watch?v=MJBZIDoNf1w			



Last Dimmer



Professioneller Dimmer ETC 12k. Dimmer Harting

- * 12 Kanal 2x Harting
- * 32A Anschluss
- * DMX 5 Pol

M-ETC

1



Lastkabel Multikabel Split Box

- * 16Pol Multipin male/female
- * Kabel Split Box
- * Max. Leistung/ Kanal 16A / 3600W
- * Max. Gesamtleistung 96A / 22080W

M-LKSP-Boc



Lastkabel Multikabel Kabelpeitsche

- * 16Pol Multipin male/female
- * Split Kabelpeitsche
- * Max. Leistung/ Kanal 16A / 3600W
- * Max. Gesamtleistung 96A / 22080W

M-LKKP



Lastkabel

- * Länge 2 oder 3m grau
- * 16Pol Multipin male/female
- * 18x 1,5m²
- * Kabeldurchmesser 16,2mm

M-LK2

M-LK5



Lastkabel

- * Länge 10m grau
- * 16Pol Multipin male/female
- * 18x 1,5m²
- * Kabeldurchmesser 16,2mm

M-LK10



Lastkabel

- * Länge 15m grau
- * 16Pol Multipin male/female
- * 18x 1,5m²
- * Kabeldurchmesser 16,2mm

M-LK15





Lastkabel

- * Länge 20m grau
- * 16Pol Multipin male/female
- * 18x 1,5m²
- * Kabeldurchmesser 16,2mm

M-LK20

	1 Kanal Dimmerpack 10A	M-DP1K		
	* Kompakter 1 Kanal DMX Dimmer			

	4 Kanal Dimmerpack	M-DP4K		
	* Kompakter 4 Kanal DMX			
	*			

	Hazebase 19"	M-MHazer		
	* Dunsterzeuger ohne Kompressor			
	* geringer Fluidverbrauch			
	* Beweglicher Nebelaustritt			
	* 1500W			
			1	

	Manfrotto Wind Up Lichtstativ	M-LSt-k		
	* 2 Auszüge mit Kurbel			
	* Standfläche 128cm			
	* 1,65 - 3,8m			
	* Gewicht 21,3kg			
			2	

	Manfrotto Cine Stativ	M-LSt-g		
	* mit 3-teiliger Säule			
	* 1 Bein verstellbar			
	* 1,45 - 3,8m			
	* Gewicht 10kg			
			2	

	Lumenradio Wireless Sender	M-LRWS		
	* Sender 2,4GHz			
	* 512 Kanäle			
	*			
			1	

	Lumenradio Wireless Empfänger	M-LRWE		
	* Sender 2,4GHz			
	* 512 Kanäle			
	*			
			1	

Power Con Kabel													
	<p>Powercon</p> <ul style="list-style-type: none"> * Schutzkontakt Stecker / Powercon * Powercon Blau 	M-PoCon-11	<table border="1"> <tr><td></td><td></td></tr> <tr><td></td><td></td></tr> <tr><td></td><td></td></tr> <tr><td></td><td></td></tr> <tr><td></td><td></td></tr> </table>										
	<p>Powercon</p> <ul style="list-style-type: none"> * Powercon Blau / Grau 	M-PoCon-12	<table border="1"> <tr><td></td><td></td></tr> <tr><td></td><td></td></tr> <tr><td></td><td></td></tr> <tr><td></td><td></td></tr> <tr><td></td><td></td></tr> </table>										
	<p>Neue PowerCon</p> <ul style="list-style-type: none"> * Schutzkontakt Stecker Neue PowerCon 	M-PoCon-13	<table border="1"> <tr><td></td><td></td></tr> <tr><td></td><td></td></tr> <tr><td></td><td></td></tr> <tr><td></td><td></td></tr> <tr><td></td><td></td></tr> </table>										
	<p>Neue PowerCon Verlängerung</p>	M-PoCon-14	<table border="1"> <tr><td></td><td></td></tr> <tr><td></td><td></td></tr> <tr><td></td><td></td></tr> <tr><td></td><td></td></tr> <tr><td></td><td></td></tr> </table>										
	<p>Neue PowerCon Verlängerung</p>	M-PoCon-15	<table border="1"> <tr><td></td><td></td></tr> <tr><td></td><td></td></tr> <tr><td></td><td></td></tr> <tr><td></td><td></td></tr> <tr><td></td><td></td></tr> </table>										
	<p>Neue PowerCon Verteiler</p> <ul style="list-style-type: none"> * 3 fach * mit Durchschleifbuchse 	M-PoCon3	<table border="1"> <tr><td></td><td></td></tr> <tr><td></td><td></td></tr> <tr><td></td><td></td></tr> <tr><td></td><td></td></tr> <tr><td></td><td></td></tr> </table>										
	<p>Neue PowerCon Verteiler</p> <ul style="list-style-type: none"> * 6 fach * mit Durchschleifbuchse * * * 	M-M-PoCon6	<table border="1"> <tr><td></td><td></td></tr> <tr><td></td><td></td></tr> <tr><td></td><td></td></tr> <tr><td></td><td></td></tr> <tr><td></td><td></td></tr> </table>										

DMX Kabel und Adapter

	DMX Adapter XLR3-XLR5	M-DMX53		
	* Länge: 20cm			
	* 110 Ohm Kabel			
	* XLR 3 Pol Stecker			
	* XLR 5 Pol Buchse			

	DMX Adapter XLR5-XLR3	M-DMX35		
	* Länge: 20cm			
	* 110 Ohm Kabel			
	* XLR 5 Pol Stecker			
	* XLR 3 Pol Buchse			

	DMX Endstecker 3 Pol	M-DMXEST3		
	* XLR 3 Pol Stecker			
	* Endwiderstand 110 Ohm			

	DMX Endstecker 5 Pol	M-DMXEST5		
	* XLR 5 Pol Stecker			
	* Endwiderstand 110 Ohm			

	DMX Kabel 5 Pol	M-DMX5-3		
	* Länge 3m			
	* 5 Pol Stcker 5 Pol Kupplung			

	DMX Kabel 5 Pol	M-DMX5-10		
	* Länge 10m			
	* 5 Pol Stcker 5 Pol Kupplung			

	DMX Kabel 5 Pol	M-DMX5-25		
	* Länge 25m			
	* 5 Pol Stcker 5 Pol Kupplung			

Rigging Bühne



Stahlseile / Sicherungsseile

- * Stahlseil 0,5m
- * Stahlseil 0,75m
- * Stahlseil 1,0m
- * Stahlseil 1,5m
- * Stahlseil 2,0m
- * Stahlseil 3,0m

M-SiSeil-05		
M-SiSeil-75		
M-SiSeil-10		
M-SiSeil-15		
M-SiSeil-20		
M-SiSeil-30		



Rundschlinge Steelflex

- * DIN EN1492-2; EN13414-1; EN13414-3
- * extrem hohe Belastbarkeit 5-fache Sicherheit
- * entsprechend den DGUV17 (BGVC-1)
- * keine Sekundärsicherung notwendig
- * Produktkennzeichnung mit eingewebter Länge und Tragkraft

M-P350konf2		



Bühnenmolton

- * Verschiedene Breiten und Längen
- * Unterschiedliche Farben
- * B1 Zertifiziert
- * Schwer entflammbar
- *

M-Molton		



Reutlinger Drahtseilhalter

- * Professioneller Drahtseilhalter
- * Tragkraft bis 90kg
- * Stahlseil zur Benutzung mit Reutlinger 6m

M-Reutlinger		



Kettenzug 250

- * Kompakt und leicht
- * Serienmäßige Überlastsicherung (ab 500 kg Tragfähigkeit)
- * Vergütete, galvanisierte Lastkette nach DIN EN 818-7-T

M-Kettenzug		



Schäkel und Kleinmaterial

- * geschweißte Schäkel
- * mit durchgehendem Bolzen: rot, grün oder blau lackiert
- * gesichert durch Mutter und Splint
- * Sicherheitsfaktor 6:1
- * qualitätsgeprüft

M-Schaekel		

Verschiedenes



Bühnenpodest Indoor

M-BP200x100

- * Podestplatte 200 x 100 x 9cm
- * TÜV geprüft
- * Traglast: 750 kg pro m²
- * mit 4 Podestfüßen 15, 20, 30, 40, 60cm



Bühnenpodest Indoor

M-BP100x100

- * Podestplatte 100 x 100 x 9cm
- * TÜV geprüft
- * Traglast: 750 kg pro m²
- * mit 4 Podestfüßen 15, 20, 30, 40, 60cm



Bühnenpodest Indoor

M-BP100x050

- * Podestplatte 0,5 x 0,5 x 9cm
- * TÜV geprüft
- * Traglast: 750 kg pro m²
- * mit 4 Podestfüßen 15, 20, 30, 40, 60cm



Kabelbrücke Adam Hall Defender Office

M-KBD0,5

- * Länge: 870mm
- * Brandschutz B1(DIN4102)
- * Antirutsch-Oberfläche
- * Polyurethane schwarz
- * Indoor-Anwendungen



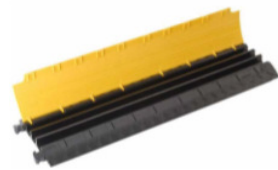

Kabelbrücke

M-KB100

- * Länge: 1m
- * Breite 29cm
- * Höhe: 4,8cm
- * Belastbarkeit: 2 t
- * Material: Polyurethane schwarz / gelb



Kabelmatten / Gummimatten

M-PGM

- * 0,5x5m
- *
- *
- *
- *

Verschiedenes

	Doughty Beam Clamp T29870	M-DBC	
	* 1.000kg		
	* Klammer zur Befestigung an Stahlträgern		
	* Für Stahlträger von: 75 - 220 mm		

	Showtec TentClamp Metal	M-TCM	
	* Traglast 150kg		

	Fadenvorhang	M-FV3x4	
	* 3x4m		

	Fadenvorhang	M-FV3x6	
	* 3x6m		

	Loungesessel Leder schwarz	M-Sesel-sw	
	*		

	Loungesessel Leder weiß	M-Sesel-ws	
	*		

Audio Set

	Audio Set 1	M-PAS1	
	<ul style="list-style-type: none"> * Aktiv Lautsprecher 80W mit AKKU und Netzbetrieb * integrierter CD Player und SD Slot * LS Stativ * Funk Mikro 864MHz 		



	Audio Set 1M	M-PAS2	
	<ul style="list-style-type: none"> * 2x Aktiv Lautsprecher 80W mit AKKU und Netzbetrieb * integrierter CD Player * 2x LS Stativ * Funk Mikro 864MHz 		



	Audio Set 3 Weiß	M-PAS3	
	<ul style="list-style-type: none"> * 2x Aktiv Lautsprecher 40W mit AKKU und Netzbetrieb * integrierter CD Player und SD Slot * 2x LS Stativ weiß * 2x Funk Mikro Sennheiser e Band 		

	Audio Set 4	M-PAS4	
	<ul style="list-style-type: none"> * Yamaha Power Mischer EX 5000 * 2 K&F Lautsprecher mit Stativ und 2x 10m LS Kabel * Line 6 Handmikro 2,4GHz * 3,5mm Kabel für Zuspeler 		

Licht Set



	Licht Set 1	M-PLS1	
	<ul style="list-style-type: none"> * 4x BT310 LED 12x 6W * LED, automatischer Farbwechsel * Sound to Light * Statische Farben 		

	Licht Set 2	M-PLS2	
	<ul style="list-style-type: none"> * 6x Litecraft AT10 * IP65 Outdoor * 18x 10W LED Chips * Stufenlos dimmbar * DMX 512 		

	Licht Set 3	M-PLS3	
	<ul style="list-style-type: none"> * 6x BeamZ PAR56 LED * Indoor * 12x 10W LED Chips * Stufenlos dimmbar * DMX 512 		

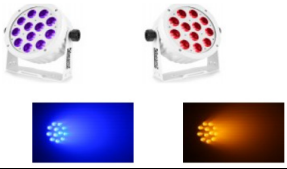
	Licht Set 4 * 6x Litecraft AT10 * 4x BeamZ * 2x LED 4er Mit Stativ	M-PLS4		

	Licht Set 5 weiß * 6x BAC506W BeamZ * 12x18W LED RGBAW - UV * DMX und Stand Alone Mode * Pre programmed shows	M-PLS5		

	Licht Set 6 weiß * 6x BAC404W BeamZ * 4 x18W LED RGBAW - UV * DMX und Stand Alone Mode * Pre programmed shows	M-PLS5		

Video Set

	Video Set 1 * Beamer 2000/ 3000 Lumen * 4:3 und 16:9 ; Nativ XGA Auflösung *	M-PVS1		

	Video Set 2 * Beamer 3000/4000 Lumen * 4:3 und 16:9 ; Nativ XGA Auflösung	M-PVS2		

	Video Set 3 * Beamer 3000/4000 Lumen * 4:3 und 16:9 ; Nativ XGA Auflösung * Stativleinwand 200x200	M-PVS3		

	Video Set 4 * Beamer 4000/5000 Lumen * 4:3 und 16:9 ; Nativ WXGA Auflösung * Stativleinwand 200x200 * Beamertisch; Aktiv Lautsprecher	M-PVS4		

Party Pakete





Party Paket 1

M-PP1

- * 6x Litecraft AT10 silber automatischer Farbwechsel
- * Sound to Light, statische Farben, Kabel
- * 1 Aktiv Lautsprecher, 1 Stativ
- * integrierter CD Player, USB MP3 Player, SD Kartenslot,
- * Hand Mikro



Party Paket 2

M-PP2

- * 6x Litecraft AT10 silber automatischer Farbwechsel
- * Sound to Light, statische Farben, Kabel
- * 1 Paar Aktiv Lautsprecher, 2 Stative
- * integrierter CD Player, USB MP3 Player, SD Kartenslot,
- * Hand Mikro



Party Paket 3

M-PP3

- * Beamer
- * Lautsprecher
- * Leinwand
- * Hand Mikro



Party Paket 4

M-PP4

- * Beamer
- * Lautsprecher
- * Leinwand
- * Lichtpaket
- * DJ Player



Licht Set 2 Astera AX3

M-PLS2

- * ASTERA AX3
- * 8x LED Spots 15W RGB
- * klein und kompakt
- * Betriebsdauer 5-20 Stunden
- * Fernbedienung
- * Laden im Transportkoffer



Funkgeräte

	Motorola Funkgeräte set 6	M-MGP340set6		
	<ul style="list-style-type: none"> * 6x Motorola GP340 * 6x Ersatz Akku * 6x Headset * Motorola Schnell-Ladegerät * Case 			

	Motorola Funkgeräte set 10	M-MGP340set10		
	<ul style="list-style-type: none"> * 10x Motorola GP340 * 10x Ersatz Akku * 10x Headset * Motorola Schnell-Ladegerät * Case 			

Intercom

	ASL Intercom Master Station set	M-ASLMS		
	<ul style="list-style-type: none"> * ASL Masterstation * ASL Beltback * 2x ASL Headset 			

	ASL Headset und Beltback	M-ASL B+H		
	<ul style="list-style-type: none"> * ASL Beltback * ASL Headset 			

	Wii Spielkonsole	M-Wii		

	X Box	M-xBox		



Zelt, schwarz

M-Zelt

- * Zelt Dach und Seitenteile schwarz
- * einfach aufzubauen 3 x 4,5m
- * Durchgangshöhe: 1,9 - 2,1m
- * FoH Zelt
- * Faltpavillon



Quiz-Buzzer SYSTEM

4 Buzzer

M-Buzzer

- * Zentraleinheit mit 4 Buzzer
- * Geschicklichkeit - im richtigen Moment den Auslöser zu buzzern
- * Ein blinkendes LED-Lichtband zeigt den Erstgedrückten
- * wird ein Buzzer gedrückt, sind die anderen 3 für 30 Sekunden gesperrt
- * Die Sperrung erfolgt innerhalb von 0,0001 Sekunden



IVS Interaktives Voting System

M-Voting

- * incl. 60 Keypads



iclip Handy

M-iclipH

- * iclip Expand für Handy



iclip Tablet

M-iclipT



- * iclip Expand für Tablet
- * bis 30,7cm / 12,1 Zoll





Moderatoren Koffer

M-Mod-Koffer

- * incl. Verbrauch

	<p>Pinwand</p> <ul style="list-style-type: none"> * Beidseitig nutzbar * 150x120cm * Stabiler Metallrahmen * Nadeln leicht einsteckbar * mobil 	<p>M-Pinwand</p>	<table border="1"> <tr><td></td><td></td></tr> <tr><td></td><td></td></tr> <tr><td></td><td></td></tr> <tr><td></td><td></td></tr> <tr><td></td><td></td></tr> <tr><td></td><td></td></tr> <tr><td></td><td></td></tr> <tr><td></td><td></td></tr> </table>																
	<p>FlipChart</p> <ul style="list-style-type: none"> * Format 65x105 * höhenverstellbar * Magnethaftend * 5 Rollen * mobil 	<p>M-FlipChart</p>	<table border="1"> <tr><td></td><td></td></tr> <tr><td></td><td></td></tr> <tr><td></td><td></td></tr> <tr><td></td><td></td></tr> <tr><td></td><td></td></tr> <tr><td></td><td></td></tr> <tr><td></td><td></td></tr> <tr><td></td><td></td></tr> </table>																
	<p>DVBT-2 set</p> <ul style="list-style-type: none"> * Kathrein DVBT-2 Antenne * DVBT-2 Receiver * 1080i/50 	<p>M-DVBT</p>	<table border="1"> <tr><td></td><td></td></tr> <tr><td></td><td></td></tr> <tr><td></td><td></td></tr> <tr><td></td><td></td></tr> <tr><td></td><td></td></tr> <tr><td></td><td></td></tr> <tr><td></td><td></td></tr> <tr><td></td><td></td></tr> </table>																
	<p>SAT-SET</p> <ul style="list-style-type: none"> * Satelittenschüssel Kathrein * Standfuß * LNB 950 - 2150MHz * Satelitten Receiver HD mit HDMI OUT * LCD 90 Kathrein Kabel bis 50m 	<p>M-SAT-set</p>	<table border="1"> <tr><td></td><td></td></tr> <tr><td></td><td></td></tr> <tr><td></td><td></td></tr> <tr><td></td><td></td></tr> <tr><td></td><td></td></tr> <tr><td></td><td></td></tr> <tr><td></td><td></td></tr> <tr><td></td><td></td></tr> </table>																
	<p>Kabelreceiver</p> <ul style="list-style-type: none"> * HDTV Receiver für Kabelempfang * Empfang aller freien digitalen TV Programme * HDMI und Scart Anschluss * Analoger Audio Ausgang * 1080i/50 / 720p / 576p 	<p>M-Kabel</p>	<table border="1"> <tr><td></td><td></td></tr> <tr><td></td><td></td></tr> <tr><td></td><td></td></tr> <tr><td></td><td></td></tr> <tr><td></td><td></td></tr> <tr><td></td><td></td></tr> <tr><td></td><td></td></tr> <tr><td></td><td></td></tr> </table>																
	<p>Megaphone</p> <ul style="list-style-type: none"> * 	<p>M-Megaphone</p>	<table border="1"> <tr><td></td><td></td></tr> <tr><td></td><td></td></tr> <tr><td></td><td></td></tr> <tr><td></td><td></td></tr> <tr><td></td><td></td></tr> <tr><td></td><td></td></tr> <tr><td></td><td></td></tr> <tr><td></td><td></td></tr> </table>																

	Gaffa schwarz; silber; weiß * Profi Gewebe Klebeband * 5cm x 50m * Matt, wasserfest, beschriftbar	M-Gaffa-sw		

	Gaffa * Profi Gewebe Klebeband * 5cm x 50m * Matt, wasserfest, beschriftbar	M-Gaffa-Col		

	Gaffa * Profi Gewebe Klebeband * 5cm x 50m * Matt, wasserfest, beschriftbar	M-Gaffa-SwGe		

	Brandschutz & Erste Hilfe * Emergency Case * Feuerlöscher * Löschdecke * Verbandskasten * Megaphone	M-Brandschutz		

	Laderampen * 2 Stück 2m	M-Laderampen		

	Hubwagen * Gabelhubwagen 2,5t Tragkraft * Kugelgelagerte Lenk- und Lastrollen aus Polyurethan * 210° nach rechts und links drehbare Deichsel * Hydraulikpumpe in Stahlausführung	M-Hubwagen		

	Anhänger * 1.300kg * geschlossener Kasten * gebremst	M-Anhänger		

200 QUADRATMETER MOBILE ALMHÜTTE

auf Anfrage



Bild: Hifi Klang Elektronische Medien / Siege Bildnachweise

Eine **Almhütte** für Ihre Veranstaltung: Eine außergewöhnliche, mobile Location. Temporär nutzbar, aber umso gemütlicher. Urig, aber umso exklusiver. Eine 200 Quadratmeter große Almhütte, komplett aus Holz mit 120 Quadratmetern Terrasse. Die mobile Location ist für viele Events geeignet und bietet Raum für bis zu 200 Gäste. Ihre Gäste werden vom Ambiente der Hütte begeistert sein. Und auch die Ausstattung unserer mobilen Location lässt keine Wünsche offen. Wir konfigurieren die Almhütte jedes Mal wieder neu, entsprechend Ihren Wünschen und Vorstellungen. Rufen Sie uns an und sprechen Sie mit unseren Experten. Wir beraten Sie gerne!

AUFTEILUNG

- 120 qm Hauptraum
- 80 qm Jagdstube
- 120 qm Terrasse

Unterm Strich: Platz für rund 200 Personen auf insgesamt 320 Quadratmetern

AUSSTATTUNG

Nach Ihren Wünschen, Bedürfnissen und Vorstellungen frei konfigurierbar:

- Küche
- Musikanlage
- Sanitäre Einrichtungen
- Personalbereiche
- Cateringbereiche
- Thekenanlage
- Individuelle Ausstattung und Dekoration

ANFORDERUNGEN

- Platzbedarf für 40to Kran
- Zeitbedarf: 2 Tage für den Aufbau, 1 Tag für die Dekoration, 2 Tage für den Abbau

Strom			
	Schuko Verteiler 3 fach	M-SV3	
	* 3600W		
	Schuko Verteiler 6 fach	M-SV6	
	* 3600W		
	Schuko Kabel Verlängerungskabel 5m	M-SVK-5m	
	Schuko Kabel Verlängerungskabel 10m	M-SVK-10m	
	Schuko Kabel Verlängerungskabel 20m	M-SVK-20m	
	CEE-Rot 16A Drehstrom-Kabel 5m	M-CEE16-5	
	CEE-Rot 16A Drehstrom-Kabel 10m	M-CEE16-10	
	CEE-Rot 16A Drehstrom-Kabel 20m	M-CEE16-20	
	CEE-Rot 32A Drehstrom-Kabel 5m	M-CEE32-5	
	CEE-Rot 32A Drehstrom-Kabel 10m	M-CEE32-10	
	CEE-Rot 32A Drehstrom-Kabel 15m	M-CEE32-15	
	CEE-Rot 64A Drehstrom-Kabel 5m	M-CEE64-5	
	CEE-Rot 64A Drehstrom-Kabel 10m	M-CEE64-5	
	CEE-Rot 64A Drehstrom-Kabel 15m	M-CEE64-5	
	Strom Unterverteiler	M-16StUV-3	
	* 16A / 3x Schuko		
	Strom Unterverteiler	M-16StUV-FI	
	* 16A / 6x Schuko mit FI		
	Strom Unterverteiler	M-32StUV-FI	
	* 32A / 5x Schuko mit FI		

www.berger-me.de	BERGER media & event	Tel. 0621 59 800 0		
Mietkatalog 2023-02	Frau Berger-Gillich	mbg@berger-me.de		